

Headquarters

# EFFECTS OF PILE DRIVING SOUNDS ON NON-AUDITORY TISSUES OF FISH

## Final Report

January 2013

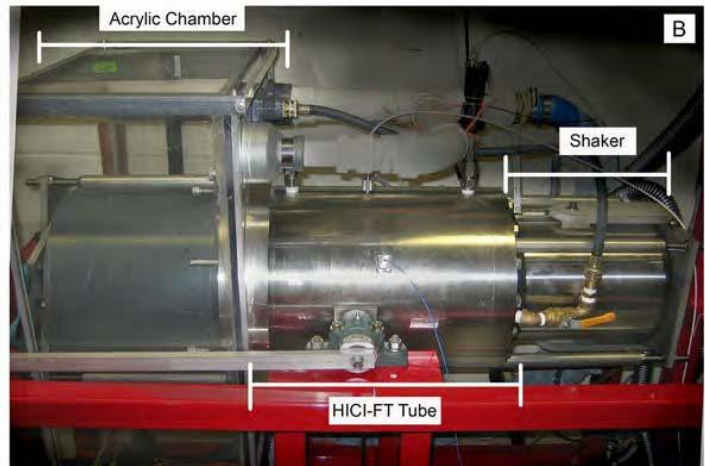

**U.S. Department of the Interior  
Bureau of Ocean Energy Management  
Headquarters, Division of Environmental Sciences  
[www.boem.gov](http://www.boem.gov)**



# **EFFECTS OF PILE DRIVING SOUNDS ON NON-AUDITORY TISSUES OF FISH**

## **Final Report**

### **Authors**

Arthur N. Popper  
Michele B. Halvorsen<sup>1</sup>  
Brandon M. Casper  
Thomas J. Carlson<sup>1</sup>

**Prepared under BOEM Contract  
M08PC20010**

**By  
University of Maryland  
Department of Biology  
College Park, MD 20742**

**Published by  
U.S. Department of the Interior  
Bureau of Ocean Energy Management  
Headquarters, Division of Environmental Sciences**

**Herndon, Virginia  
January 2013**

---

<sup>1</sup> *Current address: Battelle-Pacific Northwest National Laboratory, Marine Science Laboratory, Sequim, WA 98382*

## **DISCLAIMER**

This report was prepared under contract between the Bureau of Ocean Energy Management (BOEM) and the University Maryland. This report has been technically reviewed by BOEM, and it has been approved for publication. Approval does not signify that the contents necessarily reflect the views and policies of BOEM, nor does mention of trade names or commercial products constitute endorsement or recommendation for use. It is, however, exempt from review and compliance with BOEM editorial standards.

## **REPORT AVAILABILITY**

This report is available for downloading at the [Environmental Studies Program Information System \(ESPIS\)](#) by referencing OCS Study BOEM 2012-105.

## **CITATION**

Popper, Arthur N., Michele B. Halvorsen, Brandon M. Casper, and Thomas J. Carlson. 2013. U. S. Dept. of the Interior, Bureau of Ocean Energy Management, Headquarters, Herndon, VA. Effects of Pile Sounds on Non-Auditory Tissues of Fish. OCS Study BOEM 2012-105. 60 pp.

## ACKNOWLEDGEMENTS

This project was supported by the Bureau of Ocean Energy Management, (BOEM - formerly Minerals Management Service), California Department of Transportation (Caltrans), and National Cooperation of Highway Research Programs (NCHRP 25-28) / Transportation Research Board (TRB). In particular, we thank our project manager at BOEM, Elizabeth Burkhard, for her guidance and insight, David Buehler of ICF for managing our project with Caltrans and for his expert advice, and Jim Laughlin (WSDOT) for providing pile driving signals recorded from Eagle Harbor pile installations. We are grateful to William Ellison (Marine Acoustics Inc.), Richard Fay (Loyal University of Chicago), Mardi Hastings (Georgia Institute of Technology), A.D. Hawkins (Loughine Ltd), David Mann (University of South Florida), James Martin (Georgia Institute of Technology), Peter Rogers (Georgia Institute of Technology), and David Zeddies (Marine Acoustics Inc.) for their support and guidance during the course of this study. Special thanks to James Martin for building and delivering the HICI-FT to University of Maryland, and for countless hours on the phone trouble shooting and advising.

We also thank Dr. Jiakun Song, David Sanderson-Kilchenstein, Frazer Matthews, and Sara Therrien for their outstanding help during various parts of this project. John Stephenson, Timothy Linley, and Piper Benjamin of the Pacific Northwest National Laboratory in Richland, Washington were supportive in fish husbandry and in preparing, sorting, and shipping the fish to Maryland. Finally, we extend our appreciation to facilities management personnel at the University of Maryland for their care, expertise, and speed at handling the demands this experiment required of plumbing, HVAC, and electrical work; we specifically thank Del Propst, Brian Brevig, Steve Russo, Dave Dalo, and Richard Tucci.

Arthur N. Popper  
Michele B. Halvorsen  
Brandon B. Casper  
Thomas J. Carlson

## TABLE OF CONTENTS

List of Figures .....	viii
List of Tables .....	viii
Abbreviations .....	ix
Executive Summary .....	x
1.0 Introduction .....	1
1.1 What is Known about Effects of Pile Driving on Fish? .....	1
1.2 Background on Sound and Terms Used in This Report .....	1
1.3 Source of Physiological Effects from Intense Sounds .....	2
1.4 Current Regulations on Exposure to Pile Driving .....	3
1.5 Study Plan .....	3
1.6 Overview of Studies and Findings .....	4
1.6.1 Effects of Exposure on Chinook Salmon (Section 3) (Published as Halvorsen et al. 2012a) .....	4
1.6.2 Recovery of Chinook Salmon (Section 4) (Published as Casper et al. 2012) .....	5
1.6.3 Effects of Sound Exposure on Hogchoker, Nile Tilapia, and Lake Sturgeon (Section 5) (Published as Halvorsen et al. 2012b) .....	5
1.6.4 Additional Studies to Be Reported Later .....	6
2.0 General Methodology .....	7
2.1 Fish and Their Maintenance .....	7
2.2 Sound Exposure Apparatus and Methods .....	7
2.3 Sound Signal Generation and Verification .....	11
2.4 General Testing Routine .....	12
2.5 Barotrauma Assessment .....	12
2.6 Quality Control .....	13
2.7 Response Variable Derivation .....	14
3.0 Study 1: Effects of Exposure on Chinook Salmon .....	16
3.1 Methods .....	16
3.1.1 Study Fish .....	16
3.1.2 General Experimental Procedures .....	16
3.1.3 Barotrauma Assessment .....	17
3.1.4 Response Variable Derivation - Fish Index of Trauma (FIT) Model .....	17
3.1.5 Statistical Analysis .....	19
3.2 Results .....	19
3.2.1 Barotrauma related to $SEL_{cum}$ .....	19
3.2.2 Data Integration .....	24
3.3 Discussion .....	25

3.3.1	Rejection of the Equal Energy Hypothesis for Impulsive Signals .....	26
3.3.2	Impulsive Sound Levels Relative to Injury Consequences .....	26
3.3.3	Application of RWI.....	27
3.3.4	Implications of Results with Change in Depth.....	27
3.3.5	Conclusion.....	28
4.0	Study 2: Recovery of Chinook Salmon .....	29
4.1	Background .....	29
4.2	Methods.....	29
4.2.1	Study Fish.....	29
4.2.2	Fish exposure.....	29
4.2.3	Evaluation of barotrauma injuries and recovery .....	30
4.2.4	Statistical Analysis .....	30
4.3	Results .....	30
4.3.1	Comparisons Between Days Within Each Treatment .....	34
4.4	Discussion .....	35
4.5	Interpretation of These Results.....	36
5.0	Study 3: Effects of Sound on Hogchoker, Nile Tilapia, and Lake Sturgeon .....	38
5.1	Background .....	38
5.2	Methods.....	39
5.3	Results .....	42
5.4	Discussion .....	49
6.0	General Conclusions.....	52
6.1	Overview of Results.....	52
6.1.1	Study Design .....	52
6.1.2	Recovery from Effects of Exposure .....	53
6.1.3	Effects on Inner Ear Tissues and Hearing – Preliminary Results .....	53
6.1.4	Generality of Findings to Other Fishes .....	54
6.1.5	Implications for Behavior.....	54
6.2	Overall Consideration of Findings .....	55
6.3	General Conclusions .....	55
6.3.1	Findings.....	55
6.3.2	Future Studies.....	56
7.0	Literature Cited.....	58

## List of Figures

Figure 2.1. Photo of the HICI-FT. ....	8
Figure 2.2. The HICI-FT as described in the text. ....	9
Figure 2.3. View inside the HICI-FT chamber (vertical position). ....	9
Figure 2.4. HICI-FT support buggy enabling device rotation for experiments. ....	10
Figure 2.5. Fish placement and HICI-FT positioning. ....	10
Figure 2.6. Two of the eight signals used in the study. ....	11
Figure 3.1. Juvenile Chinook salmon typical of those used in this study. ....	16
Figure 3.2. Examples of injuries. ....	18
Figure 3.3. Individual RWI values by $SEL_{cum}$ for 1920 and 960 impulses and controls. ....	20
Figure 3.4. Individual RWI values by $SEL_{ss}$ for 1920 and 960 impulses and controls. ....	21
Figure 3.5. Frequency of barotrauma injury occurrence per fish. ....	22
Figure 3.6. Number of injuries within each injury category. ....	23
Figure 3.7. $SEL_{cum}$ vs. $\ln(RWI+1)$ for all Treatments. ....	24
Figure 3.8. Contour plots of experimental space. ....	25
Figure 4.1. Photos of example injuries. ....	32
Figure 4.2. The frequency of occurrence of injuries from Exposure 1, 2, and controls. ....	33
Figure 4.3. Number of observed injuries. ....	34
Figure 4.4. Injury index values for Chinook salmon. ....	35
Figure 5.1. Examples of internal anatomy in hogchoker. ....	42
Figure 5.2. Examples of internal anatomy of the Nile tilapia. ....	43
Figure 5.3. Examples of internal anatomy of the lake sturgeon. ....	44
Figure 5.4. Frequency of occurrence of injuries. ....	45
Figure 5.5. Number of injuries observed in each fish. ....	46
Figure 5.6. Average RWI values. ....	47

## List of Tables

Table 2.1. Potential injuries. ....	13
Table 2.2. Coding of fish to determine acceptability in the data analysis. ....	14
Table 2.3. List of barotrauma injuries by mathematical weight, category, and injury. ....	15
Table 3.1. Exposure Treatments listed in order of $SEL_{cum}$ and number of strikes. ....	17
Table 4.1. Summary of statistical analyses between various exposure groups. ....	31
Table 5.1. List of treatment metrics. ....	41
Table 5.2. Statistical analyses of number of injuries for sturgeon and tilapia. ....	44
Table 5.3. Statistical analyses of RWI values for sturgeon and tilapia. ....	47
Table 5.4. Statistical analyses of number of injuries between each species. ....	48
Table 5.5. Statistical analyses of RWI values between each species. ....	49



## Abbreviations

A/D	analog/digital
ANCOVA	analysis of covariance
ANOVA	analysis of variance
ATM	atmosphere
BOEM	Bureau of Ocean Energy Management
Caltrans	California Department of Transportation
dB	decibel
EEH	equal energy hypothesis
FHWG	Fisheries Hydroacoustics Working Group
FIT	Fish Index of Trauma
g	gram
GUI	graphical user interface
HICI-FT	High Intensity Controlled Impedance Fluid-filled wave Tube
hr	hour
IACUC	Institutional Animal Care and Use Committee
kPa	kiloPascal
ln	natural log
m	meter
min	minute
mm	millimeter
MS-222	tricaine methanesulfonate
NMFS	National Marine Fisheries Service
NRC	National Research Council
PVC	polyvinyl chloride
PSD	power spectral density
re	relative
RMS	root mean square
RWI	Response Weighted Index
s	second
SD	standard deviation
SEL	sound exposure level
SEL <sub>cum</sub>	cumulative sound exposure level
SEL <sub>ss</sub>	single-strike sound exposure level
SL	sound level
SPL	sound pressure level
SPL <sub>peak</sub>	peak sound pressure level
SPL <sub>rms</sub>	root mean square sound pressure level
TRB	Transportation Research Board (of NRC)
TTS	temporary threshold shift
μPa	microPascal

## Executive Summary

There is a growing concern in the United States and throughout the world that in-water pile driving used in construction of wind farms, bridges, and other projects has the potential to affect the health and survival of fishes. However, very little is known about such effects. Earlier studies, while examining the impacts on fishes at actual pile driving construction sites, suffered from the inability of the investigators to control the pile driving activities and the immense difficulties of working in the field in order to quantify effects. In order to start to quantify such effects, this study was designed to provide quantitative data to define the levels of impulsive sound that could result in the onset tissue damage resulting from rapid changes in pressure that directly affect the body gasses and thus affect body tissues (referred to as Barotrauma). Such rapid changes in pressure are generated by impulsive sound signals.

In order to examine barotrauma effects, a High Intensity Controlled Impedance Fluid-filled wave Tube (HICI-FT) was developed that enabled laboratory simulation of high-energy impulsive sounds that were characteristic of aquatic far-field, plane-wave acoustic conditions. The sounds used were based upon the impulsive sounds generated by an impact hammer striking a steel shell pile.

In the first study juvenile Chinook salmon (*Oncorhynchus tshawytscha*), a species with a physostomous swim bladder, were exposed to impulsive sounds and subsequently evaluated for physical barotrauma injuries (Chapter 3; Halvorsen et al. 2012a). Observed injuries ranged from mild hematomas at the lowest sound exposure levels to organ hemorrhage at the highest sound exposure levels. Frequencies of observed injuries were used to compute a biological response weighted index (RWI) to evaluate the physiological impact of injuries at the different exposure levels. As single strike and cumulative sound exposure levels ( $SEL_{ss}$ ,  $SEL_{cum}$  respectively) increased, RWI values increased. Based on the results, tissue damage associated with adverse physiological costs occurred when the RWI was greater than 2. In terms of sound exposure levels, an RWI of 2 was achieved for 1920 strikes by 177 dB re 1  $\mu Pa^2 \cdot s$   $SEL_{ss}$  yielding a  $SEL_{cum}$  of 210 dB re 1  $\mu Pa^2 \cdot s$ , and for 960 strikes by 180 dB re 1  $\mu Pa^2 \cdot s$   $SEL_{ss}$  yielding a  $SEL_{cum}$  of 210 dB re 1  $\mu Pa^2 \cdot s$ . These metrics define thresholds for onset of injury in juvenile Chinook salmon.

While the first study showed that there was little immediate mortality resulting from exposure to pile driving, it was realized that fishes may succumb to their barotrauma injuries at a later time. The question arose as to whether fish show increased injuries post exposure, and/or whether they could recover from injuries. To explore this, juvenile Chinook salmon were exposed to simulated high intensity pile driving signals to evaluate their ability to recover from barotrauma injuries (Chapter 4; Casper et al. 2012). Fish were exposed to one of two cumulative sound exposure levels for 960 pile strikes (217 or 210 dB re 1  $\mu Pa^2 \cdot s$   $SEL_{cum}$ ; single strike sound exposure levels of 187 or 180 dB re 1  $\mu Pa^2 \cdot s$   $SEL_{ss}$  respectively). This was followed by an assessment of injuries immediately or assessment 2, 5, or 10 days post-exposure. There were no observed mortalities from the pile driving sound exposure. Fish exposed to 217 dB re 1  $\mu Pa^2 \cdot s$   $SEL_{cum}$  displayed evidence of healing from injuries as post-exposure time increased. Fish exposed to 210 dB re 1  $\mu Pa^2 \cdot s$   $SEL_{cum}$  sustained minimal injuries that were not significantly different from control fish at days 0, 2, and 10. The exposure to 210 dB re 1  $\mu Pa^2 \cdot s$   $SEL_{cum}$  replicated the findings in a previous study that defined this level as the threshold for onset of injury. Furthermore, these data

support the hypothesis that one or two *Mild* injuries resulting from pile driving exposure are unlikely to affect the survival of the exposed animals, at least in a laboratory environment.

Another issue was whether the effects of pile driving found in juvenile Chinook salmon are applicable to other species. To test this, the study was extended to a comparative analysis of response to pile driving stimuli in the lake sturgeon (*Acipenser fulvecens*, Acipenseridae), a species with a physostomous swim bladder; the Nile tilapia (*Oreochromis niloticus*, Cichlidae), a species with a physoclistous swim bladder; and the hogchoker (*Trinectes maculatus*, Achiridae) a flatfish without a swim bladder (Chapter 5; Halvorsen et al. 2012b).

Results for the hogchoker demonstrated no observable barotrauma at the maximum sound exposure used (the same level that resulted in mortal injuries in the other tested species). The lake sturgeon and Nile tilapia showed a range of injuries. At the maximum sound exposure, Nile tilapia had the highest number and most severe injuries overall as compared to the lake sturgeon. Decreases in the exposure levels were correlated with a decrease in the number and severity of injuries for each species. Moreover, as exposure levels came nearer to the onset of injury threshold found in juvenile Chinook salmon, Nile tilapia, lake sturgeon, and Chinook salmon showed similar injury responses. Furthermore, the observed injuries became more similar between lake sturgeon, Nile tilapia, and Chinook salmon. These results imply that the presence and type of swim bladder correspond with barotrauma injuries at the higher sound exposure levels. Therefore, physoclistous fish are more sensitive to the higher sound exposure levels than physostomous fish.

The results from these studies are the first to quantify the effects of impulsive sounds on fishes. They are also the first that can provide science-based data useful for developing criteria for impulsive sources. The results also define an onset of injury in Chinook salmon at an  $SEL_{cum}$  of over 210 dB re  $1\mu Pa^2 \cdot s$  derived from 960 strikes and  $SEL_{ss}$  of 180 dB re  $1\mu Pa^2 \cdot s$ . At these levels, most of the other species were still showing moderate to mortal injuries. It wasn't until the  $SEL_{cum}$  was 207 re  $1\mu Pa^2 \cdot s$  that the other species had comparable injury scores to the Chinook salmon, suggesting other species may be a small amount more sensitive and might have a lower threshold. It is important to note the metrics used to define threshold include the number of strikes and the  $SEL_{ss}$  levels that yield the  $SEL_{cum}$  values.

Major conclusions of this study are that: (a) For all species studied, onset of barotrauma effects did not occur until the  $SEL_{cum}$  was substantially above the current interim regulations. (b) Barotrauma injuries were not observed in a species without a swim bladder (hogchoker). (c) There were differences in the sound exposure level at which barotrauma appeared in fish. In the most sensitive tested species barotrauma was seen at an  $SEL_{cum}$  of 207 dB re  $1\mu Pa^2 \cdot s$  yielded from  $SEL_{ss}$  177 dB re  $1\mu Pa^2 \cdot s$  and 960 strikes. (d) The important metrics used to define the impulsive exposure incorporate how the energy accumulated. Three recommended metrics are:  $SEL_{cum}$ ,  $SEL_{ss}$  and the number of strikes. (e) Effects from exposure to pile driving sounds appear to be consistent across species, even when there are substantial differences in fish morphology, including in both physostomous and physoclistous fishes.

# 1.0 Introduction

Pile driving is becoming increasingly important in the United States and elsewhere because of its increased use in in-water construction, and especially in construction of offshore wind farms. In-water pile driving involves repetitively hammering one or more structure-supporting piles deep into the substrate using hydraulic hammers. The hammer strike on the top of the pile produces vibrations in the piles that are transferred from the piles into the water column as well as into the substrate. The sounds produced are impulsive and have a rapid onset. Such impulsive sounds have the potential to produce tissue shearing within an ensonified animal and this has the potential to damage tissues. Thus, there is growing concern about the potential to harm to fishes and other marine life from pile driving.

## 1.1 What is Known about Effects of Pile Driving on Fish?

While the concern for effects of pile driving is growing (reviewed in Popper and Hastings 2009a, b; Hawkins and Popper 2012; Popper and Hawkins 2012), much of the earlier works investigating these effects have had substantial problems in experimental design and/or data acquisition and analysis, as pointed out in a recent review by Popper and Hastings (2009a). These problems arose since all of the work was done in the field during actual pile driving operations. Such work is very difficult, as the investigator is not able to control the sound or run adequate control treatments, and it is not possible to stop or modify construction schedules to meet the needs of investigators or experimental designs (e.g., Abbot et al. 2002; Ruggerone et al. 2008; Caltrans<sup>2</sup> 2010a).

It is known from field observations that fishes within 10 m or so of a pile may suffer mortality, although the specific distance will depend on the sound level produced during the pile driving operation (e.g., Caltrans 2002). However, such observations have not been quantified, and there are concerns that most fish killed never come to the surface to be identified. Thus, the actual mortality of fishes close to a pile driving operation is not known in any systematic or quantitative way. Moreover, it is not clear whether fish > 10 m from a pile driving operation are potentially harmed and would also die from exposure to the impulsive sounds.

It is worth noting, though not explored in this report, that a major concern involves the behavior of fish exposed to pile driving sounds. Because sound from pile driving propagates a considerable distance from a source, the area that is ensonified with non-lethal sound is far greater than the lethal region. Thus, it is reasonable to hypothesize that pile driving sounds affect behavior in more animals than are harmed physiologically. This issue has been discussed in detail in Popper and Hastings (2009b) and Hawkins and Popper (2012).

## 1.2 Background on Sound and Terms Used in This Report

Underwater sound levels are defined in terms of decibel (dB) relative (re) to 1 micro-Pascal ( $\mu\text{Pa}$ ). Decibel is a logarithmic unit of ratios which “compresses” very large differences of sound level (e.g., from the sound of a light breeze to the sound of a nearby clap of thunder) into a

---

<sup>2</sup> In Literature cited see California Department of Transportation (Caltrans)

manageable scale. On the log scale, 6 dB is a doubling of sound pressure level (whether in air or water).<sup>3</sup> Moreover, a 20 dB increase is a 10x increase in sound pressure.

For the purposes of this report, the following measures are defined<sup>4</sup>:

- Peak sound pressure level ( $SPL_{peak}$ ) is the maximum value of a signal, measured in dB re 1  $\mu Pa$ .
- Root mean square (rms) sound pressure level ( $SPL_{rms}$ ) is the square root of the mean squared sound pressures.
- Sound exposure level<sup>5</sup> (SEL) is the squared sound pressure over the duration of the pulse normalized to one second, measured in dB re  $1\mu Pa^2 \cdot s$ .
- $SEL_{cum}$  is the energy accumulated over multiple strikes. The rate at which the  $SEL_{cum}$  accumulates depends on the level of the single strike SEL, measured in dB re  $1\mu Pa^2 \cdot s$ .

The use of these metrics varies depending on the circumstances. Until recently, all underwater sound exposure levels were reported in terms of  $SPL_{peak}$  or  $SPL_{rms}$ . Peak generally represents the maximum sound level within a signal. RMS gives an average level of sound across a signal. Neither rms nor peak is an accurate metric for reporting impulsive sound energy (Madsen 2005). As a consequence, investigators are now using sound exposure level (SEL) since it represents the total energy in an impulsive signal (see review in Popper and Hastings 2009b). SEL was developed for use in studies of impulsive sounds effects on humans (see chapters in Le Prell et al. 2012) and is now being applied to aquatic organisms as a more appropriate metric for impulsive sound.

### 1.3 Source of Physiological Effects from Intense Sounds

Impulsive sounds generated during pile driving cause rapid changes in pressure which potentially produce several types of barotrauma effects in fishes. Barotrauma is defined as tissue damage resulting from rapid changes in pressure that directly affect the body gasses and thus affect body tissues.

There are two mechanisms for barotrauma when a fish is exposed to rapid pressure changes. One mechanism occurs when rapid pressure changes cause gas in the blood to come out of solution, resulting in the formation of bubbles inside vessels and organs. These bubbles can rupture blood vessels, capillaries, and organs, and are often mortal.

The second mechanism involves the swim bladder, a gas-filled structure in the abdominal cavities of many fish species, as well as naturally occurring micro-bubbles inside blood and

---

<sup>3</sup> See - [http://www.pbs.org/odyssey/voice/20041103\\_vfts\\_transcript.html](http://www.pbs.org/odyssey/voice/20041103_vfts_transcript.html)

<sup>4</sup> See [WWW.DOSITS.ORG](http://WWW.DOSITS.ORG) for an excellent discussion of underwater acoustics directed at a lay audience.

<sup>5</sup> Various authors use cSEL,  $SEL_{cum}$ , or other designations for cumulative SEL. In this report, we use  $SEL_{cum}$  since cSEL and other designations have a variety of meanings when searched on Google, some of which could lead to confusion and misunderstanding.

tissues. All of the bubbles expand and contract when exposed to rapid pressure changes, thereby pushing against surrounding organs and tissues, potentially injuring them. In addition, the swim bladder also has the potential to rupture from these rapid changes. Since the swim bladder is critical for buoyancy control (as well as hearing and sound production in some species), its rupture compromises the fishes' swimming performance and buoyancy control thus increasing the risk for further injury or predation.

## 1.4 Current Regulations on Exposure to Pile Driving

Current regulations on the sound levels to which fish may be exposed, as a result of pile driving activities, were developed by the Fisheries Hydroacoustics Working Group (FHWG) in 2008<sup>6</sup> (Woodbury and Stadler 2008; Stadler and Woodbury 2009). These regulations focused on developing criteria for sound exposures that produce onset of physiological injury. The FHWG group was made up of representatives of industry and regulators on the West Coast. While carefully noted as being interim and conservative, these regulatory levels are being applied throughout the West Coast by NMFS, and they have been applied at some other locations around the world. The interim criteria developed by the FHWG were an  $SPL_{peak}$  of 206 dB re 1  $\mu Pa$  and an  $SEL_{cum}$  of 187 dB re 1  $\mu Pa^2 \cdot s$  for fishes above 2 g and an  $SEL_{cum}$  of 183 dB re 1  $\mu Pa^2 \cdot s$  for fishes below 2 g. The NMFS also accepted the idea that there is a "resetting" of  $SEL_{cum}$  after 12 hours of non-exposure, after which time the exposure would again be reset to 0 (Stadler and Woodbury 2009).

## 1.5 Study Plan

Since it is not possible to resolve the uncontrollable variables inherent in field studies investigating effects of pile driving on fishes (as well as the many safety issues for investigators), a specialized device, the High Intensity Controlled Impedance – Fluid-filled wave Tube (HICI-FT), was designed and built for these studies. The HICI-FT enabled presentation of pile driving sounds, identical to real-life pile driving signals, to fish in a laboratory setting. The sounds in the HICI-FT replicate far-field pile driving sounds and all their signal characteristics including intensities equivalent to those encountered at ten meters from the source. In the laboratory, investigators had control over a range of signal parameters, such as sound intensity, duration, spectrum, duty cycle, etc. Moreover, the results were quantified, which allowed examination of:

- Effects of exposure on Chinook salmon<sup>7</sup> (Chapter 3);
- Recovery from exposure by Chinook salmon (Chapter 4);
- Effects of exposure on hogchoker, Nile tilapia, and lake sturgeon (Chapter 5);
- Exposure and recovery in striped bass (to be reported later); and,

---

<sup>6</sup> [http://www.dot.ca.gov/hq/env/bio/fisheries\\_bioacoustics.htm](http://www.dot.ca.gov/hq/env/bio/fisheries_bioacoustics.htm)

<sup>7</sup> Note, general design of the HICI-FT and the first studies on exposure in Chinook salmon, which make up parts of chapter 3 of this report, were primarily funded by the Transportation Research Board (TRB) of the National Research Council (NRC). Portions of chapter 3 and all other studies were primarily funded by BOEM, with additional support from CALTRANS.

- Effects of exposure on inner ear tissues (to be reported later).

In each case, the same basic methodology was used to expose and examine effects of pile driving sounds on fish. In these studies, fish first were exposed to pile driving sounds in the HICI-FT and then examined for effects on external and internal tissues. In the part of the study funded by the Transportation Research Board (TRB), effects on hearing and temporary loss of hearing were examined, but issues arose that did not allow for completion of that part of the project. Detailed information about the hearing study can be found in Halvorsen et al. (2011).

## 1.6 Overview of Studies and Findings

The next section provides the general methods that were used for all of the studies. Sections 3 - 5 describe specific studies in detail including methodology, results, and discussion focused on the respective research question. Finally, Section 6 is a general discussion that integrates all of the studies. The following paragraphs provide a very brief overview of the subsequent chapters.

### 1.6.1 Effects of Exposure on Chinook Salmon (Section 3) (Published as Halvorsen et al. 2012a)

The risk of effects to fishes and other aquatic life from impulsive sound produced by activities such as pile driving and seismic exploration is increasing throughout the world, particularly with the increased exploitation of oceans for energy production. At the same time, there are few data that provide insight into the effects of these sounds on fishes. The goal of this study was to provide quantitative data to define the levels of impulsive sound that could result in the onset of barotrauma to fish. A High Intensity Controlled Impedance Fluid filled wave Tube (HICI-FT) was developed that enabled laboratory simulation of high-energy impulsive sounds that were characteristic of aquatic far-field, plane-wave acoustic conditions. The sounds used were based upon the impulsive sounds generated by an impact hammer striking a steel shell pile.

Neutrally buoyant juvenile Chinook salmon (*Oncorhynchus tshawytscha*) were exposed to impulsive sounds and subsequently evaluated for barotrauma injuries. Observed injuries ranged from mild hematomas at the lowest sound exposure levels to organ hemorrhage at the highest sound exposure levels. Frequencies of observed injuries were used to compute a biological response weighted index (RWI) to evaluate the physiological impact of injuries at the different exposure levels. As single strike and cumulative sound exposure levels ( $SEL_{ss}$ ,  $SEL_{cum}$  respectively) increased, RWI values increased. Based on the results, tissue damage associated with adverse physiological costs occurred when the RWI was greater than 2. In terms of sound exposure levels, an RWI of 2 was achieved for 1920 strikes by 177 dB re  $1 \mu Pa^2 \cdot s$   $SEL_{ss}$  yielding a  $SEL_{cum}$  of 210 dB re  $1 \mu Pa^2 \cdot s$ , and for 960 strikes by 180 dB re  $1 \mu Pa^2 \cdot s$   $SEL_{ss}$  yielding a  $SEL_{cum}$  of 210 dB re  $1 \mu Pa^2 \cdot s$ . These metrics define thresholds for onset of injury in juvenile Chinook salmon.

### **1.6.2 Recovery of Chinook Salmon (Section 4) (Published as Casper et al. 2012)**

Juvenile Chinook salmon, *Oncorhynchus tshawytscha*, were exposed to simulated high intensity pile driving signals to evaluate their ability to recover from barotrauma injuries. Fish were exposed to one of two cumulative sound exposure levels for 960 pile strikes (217 or 210 dB re 1  $\mu\text{Pa}^2\cdot\text{s}$  SEL<sub>cum</sub>; single strike sound exposure levels of 187 or 180 dB re 1  $\mu\text{Pa}^2\cdot\text{s}$  SEL<sub>ss</sub> respectively). This was followed by an immediate assessment of injuries, or assessment 2, 5, or 10 days post-exposure. There were no observed mortalities from the pile driving sound exposure. Fish exposed to 217 dB re 1  $\mu\text{Pa}^2\cdot\text{s}$  SEL<sub>cum</sub> displayed evidence of healing from injuries as post-exposure time increased. Fish exposed to 210 dB re 1  $\mu\text{Pa}^2\cdot\text{s}$  SEL<sub>cum</sub> sustained minimal injuries that were not significantly different from control fish at days 0, 2, and 10. The exposure to 210 dB re 1  $\mu\text{Pa}^2\cdot\text{s}$  SEL<sub>cum</sub> replicated the findings in a previous study that defined this level as the threshold for onset of injury. Furthermore, these data support the hypothesis that one or two *Mild* injuries resulting from pile driving exposure are unlikely to affect the survival of the exposed animals, at least in a laboratory environment.

### **1.6.3 Effects of Sound Exposure on Hogchoker, Nile Tilapia, and Lake Sturgeon (Section 5) (Published as Halvorsen et al. 2012b)**

This study extended the Chinook salmon work to three additional species – Nile tilapia, lake sturgeon, and hogchoker, each with different swim bladder physiology. The hogchoker, a flatfish related to flounder, lives on the bottom of the ocean and has no swim bladder; the Chinook salmon and lake sturgeon have an open (physostomous) swim bladder; Nile tilapia has a closed (physoclistous) swim bladder.

The physostomous swim bladder has a connection, referred to as the pneumatic duct, which connects the swim bladder and the gut. The fish fills the swim bladder primarily by going to the water surface and gulping air. Air can be released when needed.

In contrast, the physoclistous swim bladder has a special gland in its wall that can extract gas from the blood and pump it into the swim bladder, and gas loss is a reverse process. Physoclistous fishes do not need to come to the water surface to get gas. Exchange in gas between the blood and swim bladder is slow.

Results for the hogchoker demonstrate no observable barotrauma at the maximum sound exposure used (the same level that resulted in mortal injuries in the other tested species). The lake sturgeon and Nile tilapia showed a range of injuries. At the maximum sound exposure, Nile tilapia had the highest number and most severe injuries overall as compared to the lake sturgeon. Decreases in the exposure levels were correlated with a decrease in the number and severity of injuries for each species. Moreover, as exposure levels came nearer to the onset of injury threshold as defined by Halvorsen et al (2012a), Nile tilapia, lake sturgeon, and Chinook salmon showed similar injury responses. Furthermore, the observed injuries became more similar between lake sturgeon, Nile tilapia, and Chinook salmon. These results imply that the presence and type of swim bladder correspond with barotrauma injuries at the higher sound exposure levels. Therefore, physoclistous fish are more sensitive to the higher sound exposure levels than physostomous fish.



## **1.6.4 Additional Studies to Be Reported Later**

### **1.6.4.1 Exposure and Recovery of Striped Bass**

The initial studies documented effects on Chinook salmon (Section 3) and recovery from effects (Section 4). It is important to extend findings to additional species, not only to see overall generality of recovery results, but also to continue to explore effects on fishes with different types of swim bladders. This study involved use of the striped bass. Results were generally similar to those for Chinook salmon, although levels for onset of physiological effects were at slightly lower  $SEL_{cum}$ . This may be because, unlike Chinook salmon, striped bass do not have a connection between swim bladder and the gut, and so regulation of gas is a slower process. In addition, tests were done with specimens of different sizes, with results suggesting that larger fish may actually show more damage from the same level of pile driving than smaller fish. However, such results are preliminary since the difference in size of fish was not great due to limitations in the size of the HICI-FT chamber.

### **1.6.4.2 Effects of Exposure on Inner Ear Tissues**

Of considerable concern to regulators and others is how exposure to loud sounds impacts hearing and inner ear tissues because temporary threshold shifts have been defined as the onset of injury (Popper et al. 2006). As indicated earlier, studies on hearing in Chinook salmon were inconclusive due to large variability in the audiograms, therefore a different approach was used to determine effects in the auditory system. Dr. Michael Smith of University of Western Kentucky was brought onto the team to examine the sensory cells of the inner ear after sound exposure in striped bass and Nile tilapia. The results showed very little hair cell damage in either species and the small amounts of damage that were documented were near the maximum sound levels. This was above the levels that elicit effects on non-auditory tissues, thereby indicating that barotrauma injuries are a more sensitive indicator for injury caused by sound than auditory tissues.

## 2.0 General Methodology

Section 2 discusses the general methods that were used for all of the studies. If additional methods were used in specific studies, these will be presented in their respective sections.

*In all cases, experiments were conducted under supervision and approval of the Institutional Animal Care and Use Committee (IACUC) of the University of Maryland (protocol #R-09-23). Chinook salmon were held under authority of the Maryland Department of Natural Resources (Natural Resources Articles 4-602 and 4-11A-02).*

The greater portion of this chapter, and all figures, are from Halvorsen et al. (2011) with permission from the Transportation Research Board of the National Academies of Science.

### 2.1 Fish and Their Maintenance

Each species was obtained from a different source and those details are described within each specific study Section (3-5). In all cases, when fish were received they were allowed to acclimate to new holding water and temperature. Each fish was inspected for health and placed into the holding tank. Unless otherwise indicated, fish were held for at least two weeks in their holding tanks before being included in an experiment. Fish were kept on a 14:10 hour light/dark cycle. Prior to use in an experiment fish had their caudal fin clipped for individual identification.

### 2.2 Sound Exposure Apparatus and Methods

Sound exposure was conducted in the High Intensity Controlled Impedance Fluid-filled wave Tube (HICI-FT) that was designed and constructed at Georgia Institute of Technology by Dr. Peter Rogers and Mr. Jim Martin (Lewis et al. 1998; Rogers and Lewis 1999; Martin and Rogers 2008). Mr. Martin constructed the apparatus and wrote the software Graphical User Interface (GUI) that controlled the HICI-FT.

The HICI-FT is a wave tube that uses large shakers at either end of the water chamber holding the fish to produce sounds that accurately reproduce actual pile driving sounds. The device enabled presentation of actual pile driving sounds in the laboratory and allowed for control of the various parameters associated with pile driving signals, such as exposure duration, spectra, number of strikes, etc. The parameters were adjusted to present different sound exposure levels, and number of strikes. The sound presentation was controlled using LabVIEW (National Instruments Corporation, Austin, Texas) and the signals were captured inside of the HICI-FT during experiments with a hydrophone (Brüel & Kjaer Sound & Vibration Measurement A/S, Naerum, Denmark, Model 8103) and digitized.

The HICI-FT is shown in Figures 2.1 and 2.2. The HICI-FT tube is a water-filled chamber 0.45 m long and 0.25 m internal diameter with 3.81 cm thick stainless steel walls. The tube was enclosed at both ends with a shaker mounted into an end cap. The shaker was made up of a piston driven by an electromagnetic motor, all of which was housed inside each end cap (Figure 2.2). Each shaker was driven independently with output-signals that created pressure and velocity components for the exposure signals.

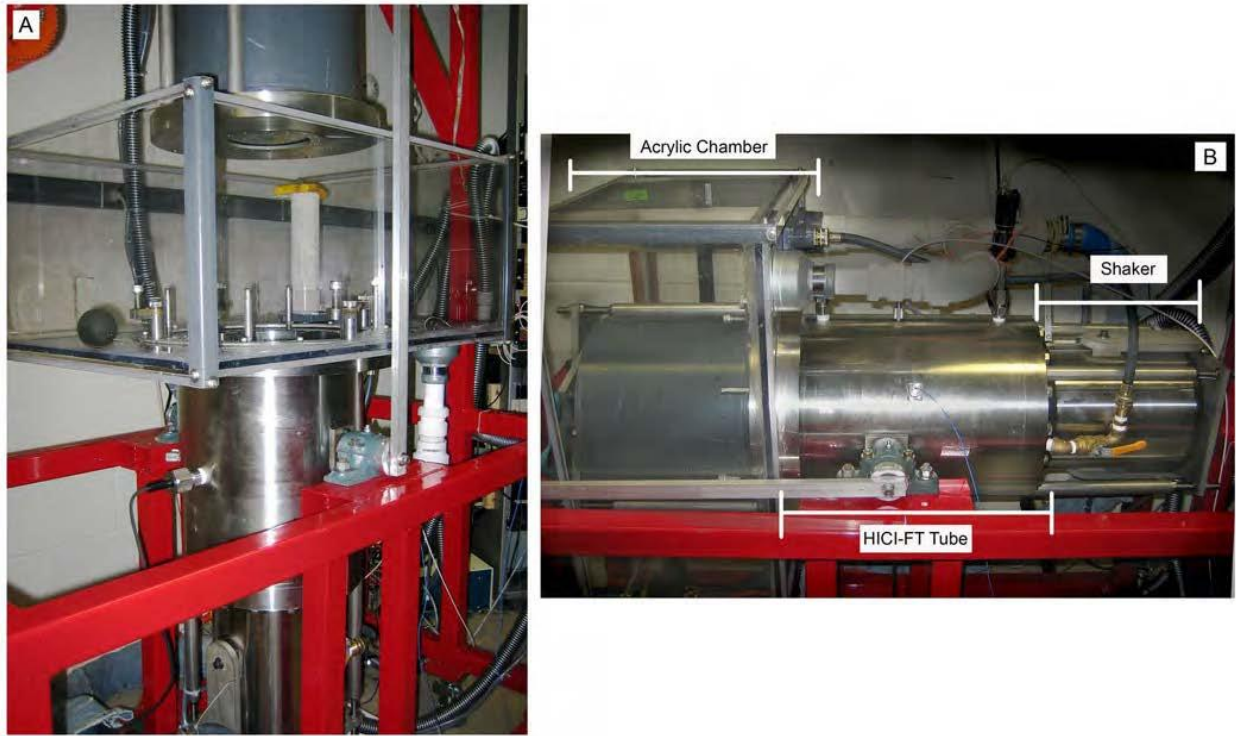

Figure 2.1. Photo of the HICI-FT.

(A) The HICI-FT in the vertical position for loading fish into the acrylic chamber. The top shaker is detached from the tube and is surrounded by gray PVC to protect it from the water in the acrylic chamber. B) During Treatments the HICI-FT is in the horizontal position. A shaker is labeled. The red structure is the supporting buggy, the white PVC pipes drain the water, and the grey hoses are part of the shaker cooling system. (From Halvorsen et al. 2012 with permission).

The inner chamber of the HICI-FT with a fish inside is shown in Figure 2.3. The tube was vertical (Figure 2.1A) when fish were placed inside and then was rotated into the horizontal orientation (Figure 2.1B) to present sound in a natural orientation with respect to the acoustic velocity vector of the incident sound field from pile driving. The manipulation of the chamber was accomplished by mounting the tube in a support buggy that allowed rotation around its center of gravity (Figure 2.4). Rotation of the device is shown in Figure 2.5.

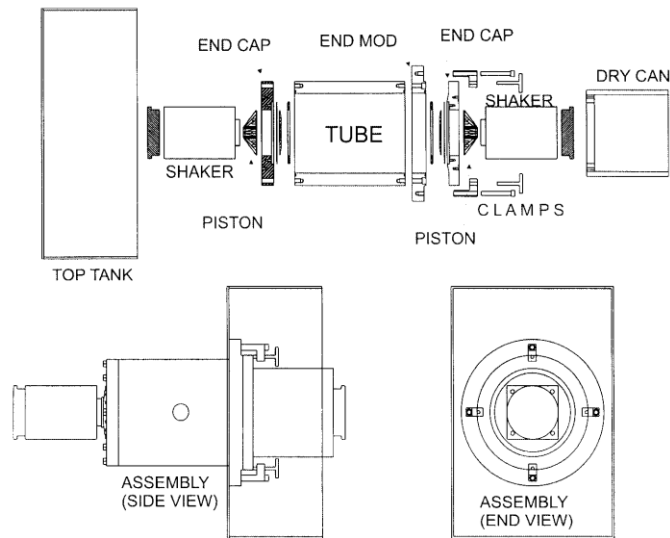

Figure 2.2. The HICI-FT as described in the text. The section labeled top tank is the acrylic water-filled chamber in which the fish were placed before exposure. The HICI-FT is shown in the horizontal position.

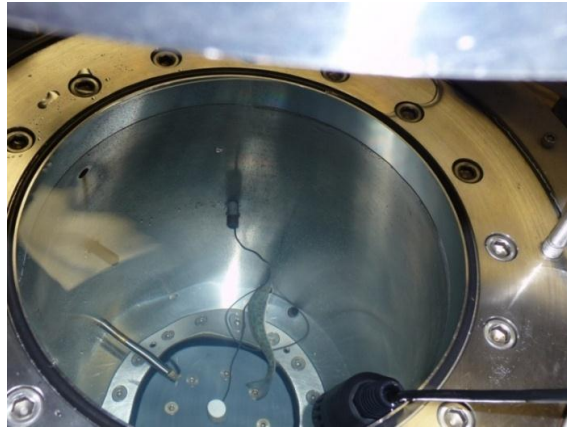

Figure 2.3. View inside the HICI-FT chamber (vertical position). A Chinook salmon can be seen toward the bottom of the tube. On the left is the hydrophone (black, small tube). The wire at the top center is the accelerometer (white cylinder attached to the bottom of the tube). The large black device (lower right) measured temperature and total dissolved gas of the water.

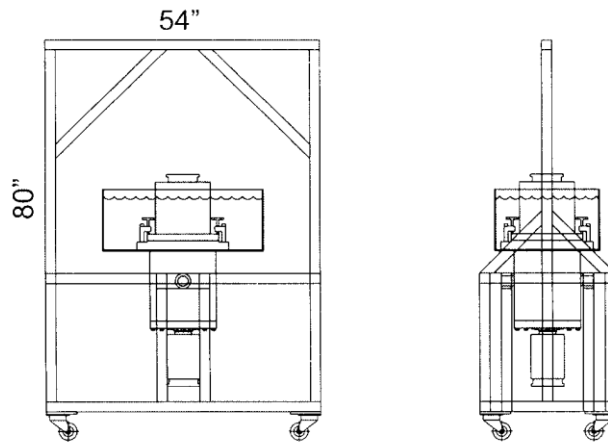

Figure 2.4. HICI-FT support buggy enabling device rotation for experiments. In this image, the HICI-FT chamber is closed and the device is in the vertical position. During operation, the wheels of the buggy were lifted off the floor by vibration isolation devices that uncoupled the buggy from the building floor.

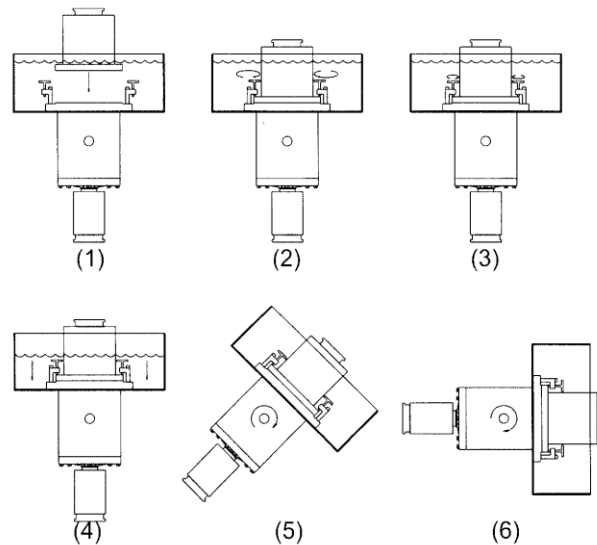

Figure 2.5. Fish placement and HICI-FT positioning. In (1), the top shaker is lifted and the chamber is open. Each fish was placed into the acrylic acclimation box (rectangle) for 20 min. After 20 min, the fish swam down into the HICI-FT tube. The top shaker was then lowered into place and clamps tightened (2) so that the top shaker was firmly mated to the rest of the HICI-FT (3). Water was then drained from the top tank (4), the HICI-FT was then rotated (5) to the testing position (6). Removing fish from the tube involved reversing these procedures.

A key feature of the HICI-FT was the use of thick and rigid steel walls, thus enabling generation of far-field plane-wave acoustic signals. Moreover, the pistons at opposite ends of the chamber could be driven in or out of phase with one another, thereby permitting modification of the pressure and particle motion fields in the chamber to generate plane wave, pure pressure, or pure particle motion signals.

### 2.3 Sound Signal Generation and Verification

The HICI-FT chamber was designed to produce propagating plane waves with a peak sound pressure level ( $SPL_{peak}$ ) of at least 215 dB re 1  $\mu$ Pa which is equivalent to signals produced by pile driving activity in the field. The pile driving signals used in this study were field recordings of both pressure and particle motion taken at a range of 10 m from a steel shell pile driven using a diesel hammer (MacGillivray and Racca 2005). The sound exposure paradigms were designed to mimic actual pile driving activities, such as the time and frequency domain characteristics of each pile strike, sound exposure levels, and number of strikes.

Eight different pile driving signals were collectively used in these experiments. Figure 2.6 shows the time domain and power spectral density of two of the eight strikes. Each signal was normalized to the same SEL and compiled into a single file of 96 strikes that represented 12 randomized repetitions of each of the 8 signals. MATLAB (The MathWorks, Inc., Natick, Massachusetts) was used each day to re-randomize the 96-strike file, which was used to generate the exposure for that day. The file was looped 10 times for a 960-strike presentation or 20 times for a 1920-strike presentation. Therefore, each day's fish received a pseudorandom presentation of pile strikes.

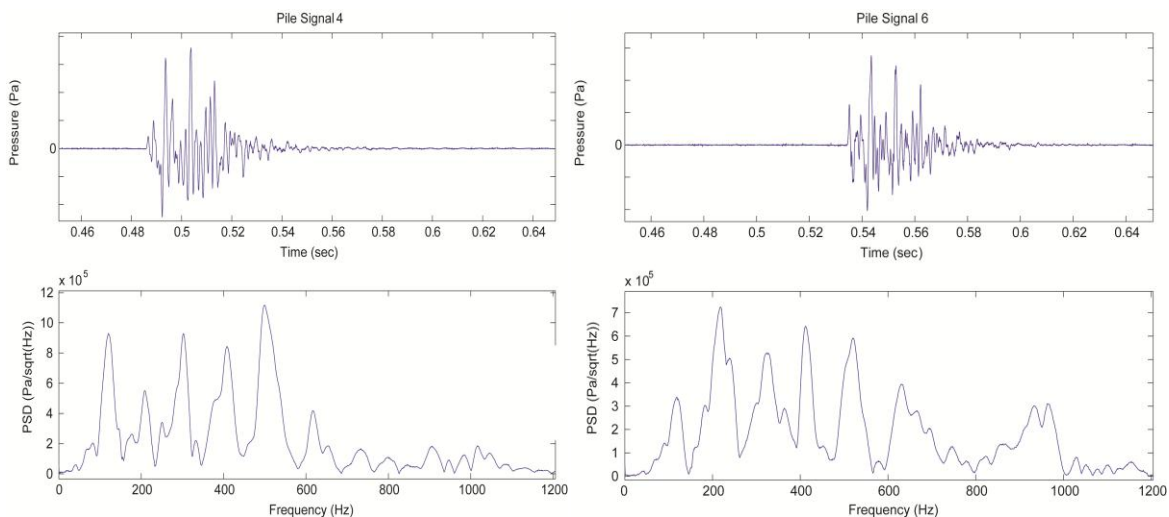

Figure 2.6. Two of the eight signals used in the study. In each figure pair, the upper image shows the time-domain of the signal while the lower panel shows the power spectral density (PSD).

A computer controlled the signal generation and data acquisition for the HICI-FT along with a 12-bit analog/digital (A/D) converter (National Instruments Corporation, Model PCI-MIO 16E1). Separate analog drive signals were filtered and attenuated using anti-aliasing filters and

programmable attenuators (Tucker-Davis Technologies [TDT], Alachua, Florida, Model PA4) and sent out on 2 channels of the A/D board. Each output was amplified by an amplifier (Crown International, Elkhart, Indiana, Model XT<sub>i</sub> 4000), before reaching its respective shaker (Vibration Test Systems, VG-150 Vibration Generator, Model VTS 150).

The signal in the HICI-FT was recorded with calibrated hydrophone (Brüel & Kjær Sound & Vibration Measurement A/S, Naerum, Denmark, model 8103), filtered by a low-noise preamplifier (SRS 560, Stanford Research Systems, Inc. [SRS], Sunnyvale, California, Model 560), digitized by the A/D board and sampled at 10 kHz. At the preamplifier, the signal was split and sent to a Marantz recorder (Marantz America, Inc., Mahwah, New Jersey, Model PMD-671) for digital storage. The signal was also fed into the software program and only partially recorded due to its size. The software used this signal to ensure that the sound level was correct. After completion of experiments the SEL<sub>cum</sub> values for each exposure were reconfirmed using the entire signal recorded.

## **2.4 General Testing Routine**

At the start of each day, the HICI-FT was filled with water and the fish were placed into the acrylic chamber for a 20 minute acclimation period. The fish were observed during this time and their final buoyancy state (negative, neutral, positive) was documented. The fish were then allowed into the HICI-FT chamber and where they were enclosed and the tube was then rotated into the horizontal exposure position. Upon completion of the exposure, the tube was rotated back into the vertical position, opened, and fish were removed. Fish were immediately necropsied and assessed for barotrauma injuries.

There were Treatment fish and Control fish. The treatment fish were exposed to a particular pile driving treatment which, depending on the number of pile strikes, had two different time durations. 1920 strikes lasted for 48 minutes and 960 strikes lasted for 24 minutes. These durations were important for the Control group as they were treated the same as their Treatment counterpart except that they did not receive a sound stimulus.

## **2.5 Barotrauma Assessment**

After exposure to impulsive sounds, fish were euthanized in a buffered MS-222 solution, necropsied, and examined for barotrauma injuries. The examination looked for external injuries as well as internal injuries, listed in Table 2.1.

Table 2.1. Potential injuries

Site of Injury	Evidence of Injury
Eyes	Hemorrhage or embolism (bubbles) (seen externally)
Stomach	Stomach protruded into oral cavity (seen externally)
Gills	Embolism in filaments of gill rakers (seen externally)
Fins	Embolism, hemorrhage, or hematoma in fin rays or base of fin (seen externally)
Anal pore	Blood or bile leakage from anal pore (seen externally)
Body cavity	Clotted or pooling blood; hematoma on musculature of body walls
Liver	Hemorrhage or hematoma of the liver
Heart	Embolism, hemorrhage, or hematoma of the heart
Spleen	Hemorrhage of spleen
Fat	Hematoma on fat
Gall bladder	Hemorrhage, hematoma, or discoloration of the gall bladder
Intestine	Hemorrhage or hematoma of the intestine; presence and amount of food in gut
Gonads	Hemorrhage or hematoma of testes or ovaries
Swim bladder	Rupturing of swim bladder; hematoma on surface; deflation without rupture
Kidney	Embolism, hemorrhage, or hematoma of the kidney; rupture of capillaries extending from the kidney

## 2.6 Quality Control

Quality control was part of the project protocols. After data were entered into a spreadsheet a second person reconciled each cell of the data set. Digital photographs were taken to document barotrauma injuries each day. At the end of data collection each fish was reviewed and determined to be kept in the data set or removed following a set of criteria shown in Table 2.2. This ensured that the information in the data set was standardized. For example, fish were of similar size, and were neutrally buoyant.



Table 2.2. Coding of fish to determine acceptability in the data analysis

Fish Coding	Rationale for Coding
1 = Complete acceptance of fish	All normal – fish used in data analysis
2 = Conditional acceptance of fish	Minor issues but not enough to warrant removal from study
	Minimal amount of food in gut
	Potentially exposed to bacterial cold water disease symptoms; asymptomatic
	Transport bucket temperature > 13.5 or < 14.5°C
	Temperature at end of HICI-FT exposure >15.1°C
3 = Reject fish	Major issues to warrant removal from study
	Negatively buoyant for sound exposure – after acclimation period
	Bacterial cold water disease symptoms
	Condition factor > 1.1; derived index of weight and length
	Excessive food in gut, damage from sound due to food presence
	Abnormal morphology near cranial region; i.e., deformed eye or short jaw
	Incorrect acclimation time prior to HICI-FT exposure (normally 20 min)
	Incorrect duration for exposure in HICI-FT
	Fish dropped
	Missing data

## 2.7 Response Variable Derivation

The data set reflected binary variables (0 or 1) that expressed the presence or absence of observed external and internal barotrauma injuries. The entire injury regime was inspected and many injuries were eliminated due to lack of occurrence (i.e., embolisms were removed), and a few others were rolled into one injury score because both indicated the same injury (i.e., external sign of pericardial hemorrhage was rolled in with internal scoring of pericardial hemorrhage). Examination of the injury panel showed that not all injuries had the same physiological significance for the health of the fish following exposure. The physiological costs or effects of barotrauma are poorly understood in fish. In order to qualitatively assess barotrauma, a novel model was developed (by Drs. Halvorsen and Woodley) and applied to this study and a concurrent study considering the effects of implosive sound from underwater rock blasting (Carlson et al. 2011). The physiological significance of each injury was determined using available literature (Husum and Strada 2002, Oventunji et al. 2010) and proposed energetic costs based on an understanding of injury (Gaspin 1975; Iwama et al. 1997; Govoni et al. 2003, 2008; Woodley and Halvorsen, personal observations 2010).

Physiological significance of each injury for fish health (Figure 2.3) was assessed, grouped together and assigned a weight (5, 3, or 1). The injuries were separated into three groups: *Mortal*, *Moderate*, and *Mild*. *Mortal* injuries (weighted 5) were those considered severe enough to lead to mortality. *Moderate* injuries (weighted 3) were those likely to adversely impact fish health; recoverable without being mortal. Finally, *Mild* injuries (weighted 1) potentially had some physiological cost to fish health (Krischer 1979; Chawda et al. 2004).

Table 2.3. List of barotrauma injuries by mathematical weight, category, and injury

<b>Wt.</b>	<b>Category</b>	<b>Injury Description</b>	<b>Biological Significance of Injury</b>
5	Mortal	Dead within 1 hr	Dead
5	Mortal	Pericardial (heart) hemorrhage	Bleeding from heart
5	Mortal	Hepatic (liver) hemorrhage	Bleeding from liver
5	Mortal	Renal (kidney) hemorrhage	Bleeding from kidney
5	Mortal	Ruptured swim bladder	Lost ability to maintain buoyancy
3	Moderate	Intestinal hemorrhage	General loss of blood
3	Moderate	Burst capillaries along body	Decreased ability to get blood to muscle
3	Moderate	Pericardial (heart) hematoma	Potential decreased efficacy
3	Moderate	Intestinal hematoma	Decreased amount of blood flow
3	Moderate	Renal (kidney) hematoma	Blood pooling
3	Moderate	Body muscles hematoma	Potential effect on swimming ability
3	Moderate	Swim bladder hematoma	Potential effect on ability to regulate buoyancy
3	Moderate	Adipose hematoma	Caused from swim bladder
3	Moderate	Ovaries/testes hematoma	Potential short-term damage with long-term consequences
1	Mild	Blood spots on vent	Dilated capillaries near skin
1	Mild	Dorsal fin hematoma	Dilated capillaries near skin
1	Mild	Caudal fin hematoma	Dilated capillaries near skin
1	Mild	Pelvic fin hematoma	Fin is near intestinal portal system
1	Mild	Pectoral fin hematoma	Fin is near the heart portal system
1	Mild	Anal fin hematoma	Dilated capillaries near skin
1	Mild	Fully deflated swim bladder (no ruptures)	Negatively buoyant
1	Mild	Partially deflated swim bladder (no ruptures)	Negatively buoyant

A response weighted index (RWI) was calculated for each fish. The formulas used were:

$$RWI(\text{Treatment}) = \sum_i^m (W_i \times T_i)$$

where RWI = response severity index,

$i$  = injury type index,

$m = 22$ , number of injury types,

$T_i$  = the number of injury type  $i$  in a fish in a Treatment-exposed or control fish,

$W_i$  = the biological significance weight (5, 3, or 1) for injury type  $i$ .

Cumulative energy was expressed as:

$$SEL_{\text{cum}} = SEL_{\text{ss}} + 10 \log_{10} (\text{number of strikes}).$$

### 3.0 Study 1: Effects of Exposure on Chinook Salmon

With permission from PLoS ONE, Section 3 is taken verbatim from *Halvorsen, M. B., Casper, B. M., Woodley, C. M., Carlson, T. J., and Popper, A. N. (2012). Threshold for onset of injury in Chinook salmon from exposure to impulsive pile driving sounds. PLoS ONE, 7(6) e38968. doi:10.1371/journal.pone.0038968.*

#### 3.1 Methods

##### 3.1.1 Study Fish

This study used juvenile Chinook salmon provided by the Pacific Northwest National Laboratory from the Priest Rapids Hatchery in Mattawa, Washington. Test fish had an average standard length of 103 mm  $\pm$  8.75 (SD) and an average weight of 11.8 g  $\pm$  3.47 (Figure 3.1). Fish were held under the authority of the Maryland Department of Natural Resources (Natural Resources Articles 4-602 and 4-11A-02).

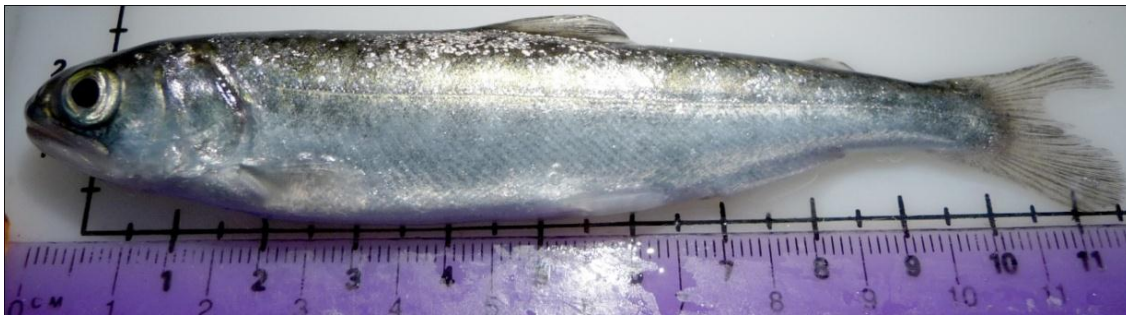

Figure 3.1. Juvenile Chinook salmon typical of those used in this study.  
Note: caudal fin clipped for identification purposes.

##### 3.1.2 General Experimental Procedures

Fish were exposed to one of eleven impulsive sound Treatments that varied in total energy - SEL<sub>cum</sub>, single strike - SEL<sub>ss</sub>, and in number of impulsive sounds (Table 3.1). Except for Treatment 1 (see below for explanation), all Treatments were conducted in pairs to achieve the same SEL<sub>cum</sub> value with either 1920 or 960 impulses. The Treatment pairs differed in the energy per impulsive sound, SEL<sub>ss</sub>. To achieve the same SEL<sub>cum</sub> value, the Treatment with 960 impulsive sound exposures needed a higher SEL<sub>ss</sub> value (concomitantly higher SPL<sub>peak</sub>) than the Treatment for 1920 impulsive sound exposures. The maximum output level that could be generated by the HICI-FT was SPL<sub>peak</sub> of 215 dB re 1  $\mu$ Pa. A Treatment producing 220 dB SEL<sub>cum</sub> over 960 impulsive sound exposures was not achievable with the HICI-FT because of the sound pressure levels required to meet the SEL<sub>ss</sub> requirement for this exposure condition. Therefore, the Treatment 1 exposure at 220 dB SEL<sub>cum</sub> could only be conducted for the 1920 impulsive sound exposures.

Table 3.1. Exposure Treatments listed in order of SEL<sub>cum</sub> and number of strikes

Treatment No.	Avg. SEL <sub>cum</sub>	Number of Strikes	Avg. SEL <sub>ss</sub>	Avg. SPL <sub>Peak</sub>	Duration, min	Exposed Fish, n	Control Fish, n	Avg. RWI
1	220	1920	187	213	48	44	33	15.34
3	216	960	186	213	24	28	10	6.07
2	216	1920	183	210	48	36	16	5.97
5	213	960	183	210	24	31	7	4.32
4	213	1920	180	207	48	26	5	2.35
8	210	960	180	208	24	31	10	4.03
9	210	1920	177	204	48	30	11	3.43
6	207	960	177	203	24	24	8	1.04
7	207	1920	174	201	48	43	17	0.58
10	204	960	174	201	24	32	11	0.66
11	204	1920	171	199	48	31	12	0.42

### 3.1.3 Barotrauma Assessment

Following exposure in the HICI-FT, and prior to barotrauma examination, fish were euthanized in a buffered solution of tricaine methanesulfonate. Fish were examined for barotrauma injuries both externally and internally then photographed to document injuries (Figure 3.2).

The investigators were trained to detect and evaluate 62 barotrauma injuries using protocols developed and validated over a number of similar investigations (Burns 2008, 2009; Brown et al. 2009; Stephenson et al. 2010; Carlson et al. 2011; Halvorsen et al. 2011). The investigators used a common methodology to assure uniformity in acquisition and logging of data. Necropsies were conducted using techniques that minimized inadvertent damage to fish organs and tissues.

### 3.1.4 Response Variable Derivation - Fish Index of Trauma (FIT) Model

To process the observed injuries, a novel model was developed by Drs. Halvorsen and Woodley (called the FIT model) that reflected onset of injury from impulsive sound (Carlson et al. 2007; Halvorsen et al. 2011). For each fish, the presence or absence of external and internal barotrauma injuries were noted in the exposure-response data set. Of the 62 potential injuries, 22 were observed during the study (Table 2.3). These injuries varied in short- and long-term physiological impacts on fish performance, such as hematoma on fins, broken capillaries, and hemorrhaging organs. Using a medical trauma approach (Husum and Strada 2002; Oyetunji et al. 2010), an anatomical scoring system was developed that provided an overall score for fish, regardless of the number of injuries. Injuries were weighted, not by severity or organ, but by known or associated energetic costs of each injury (Woodley and Halvorsen, personal communication; (Gaspin 1975; Iwama et al. 1997)). Many different injury patterns can yield the

same score (Champion 2002). Weighting allowed complex and variable data to be reduced to a single value for each fish.

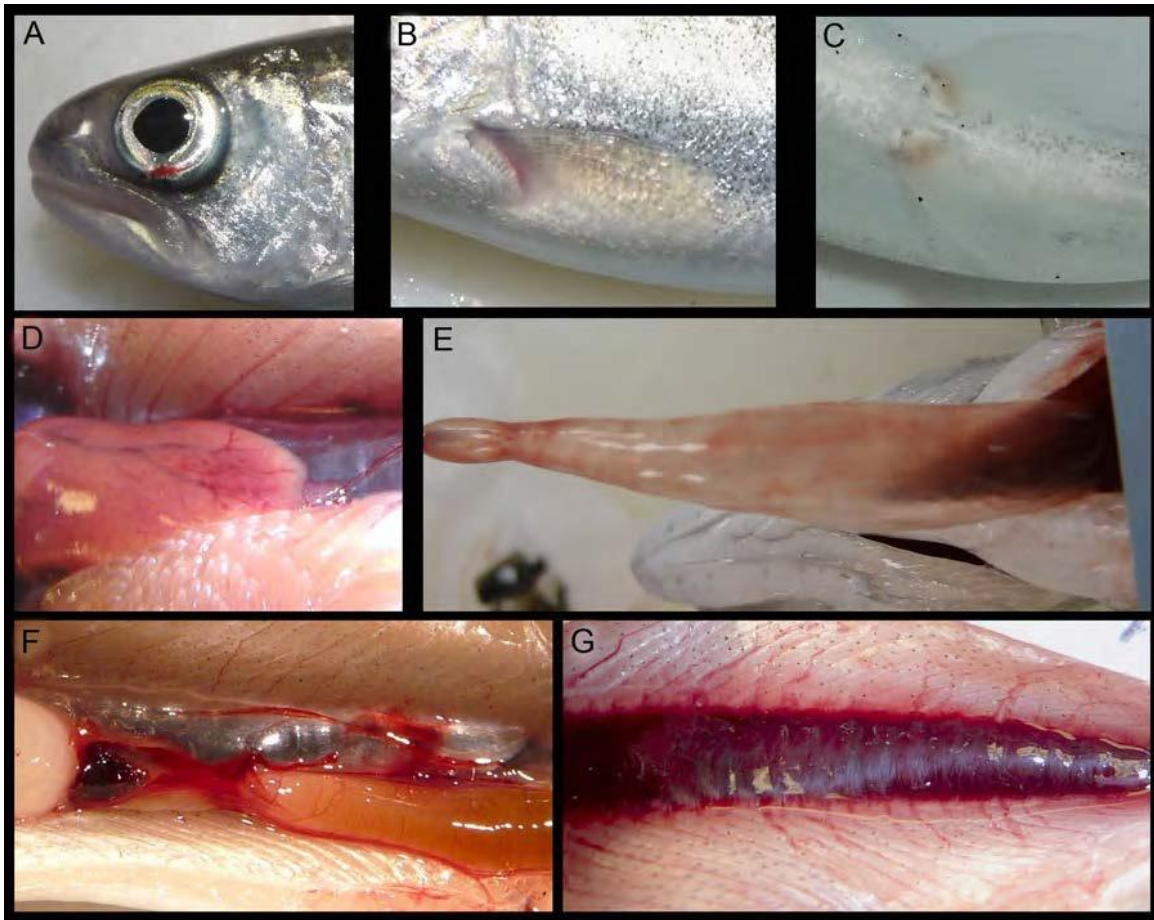

Figure 3.2. Examples of injuries.

Mild injuries are A) eye hemorrhage, B) and C) fin hematoma; Moderate injuries are D) liver hemorrhage and E) bruised swim bladder; Mortal injuries are F) intestinal hemorrhage and G) kidney hemorrhage.

Physiological impact of each observed injury was assessed, and then assigned to weighted trauma categories (Krischer 1979; Chawda et al. 2004): *Mortal*, *Moderate*, or *Mild* (see Table 2.3 for details). The *Mortal* trauma category, weighted 5, included injuries that were severe enough to lead to death. The *Moderate* trauma category, weighted 3, included injuries likely to have an adverse impact on fish health but might not lead directly to mortality. Finally, *Mild* trauma category, weighted 1, referred to injuries of minimal to no physiological cost to fish. The weight assignments applied to each of the three trauma categories were based on the assessment of physiological significance that considered the influence of multiple injuries and inspection of data for the occurrence of injury combinations. For example, the occurrence of two injuries categorized as *Moderate* were assessed to have physiological costs similar to one *Mortal* injury. Ultimately, the FIT model provided a weighted score for each fish called the Response Weighted

Index (RWI). The RWI is the sum of the presence of each injury multiplied by the trauma weight assigned to each injury type (see Section 2.7 for details).

### 3.1.5 Statistical Analysis

The response variable RWI was log transformed before analysis in order to stabilize the variance and linearize the response model. Analysis of covariance (ANCOVA) was performed regressing the transformed RWI against  $SEL_{cum}$  and assessing whether the number of impulsive sounds (960 or 1920) had an additional effect on fish response beyond that described by  $SEL_{cum}$ . Initial analyses were conducted on Treatments 2 through 11 to balance the design because Treatments 2 through 11 were paired. Once a model was selected using a balanced design, Treatment 1 was added to the model.

## 3.2 Results

Examples of injuries are shown in Figure 3.2. Each Treatment was aimed at a specific  $SEL_{cum}$  and  $SEL_{ss}$  value. However, small changes of the water compliance in the HICI-FT and small fluctuations in its mechanical operation caused slight differences in the characteristics of individual impulses and consequently the  $SEL_{ss}$  and  $SEL_{cum}$  values for individual Treatments. This produced a continuum of cumulative energy exposures ( $\pm 1.5$  dB of the target  $SEL_{cum}$ ) rather than specific  $SEL_{ss}$  and  $SEL_{cum}$  values (Figure 3.3). Exposure conditions within the HICI-FT chamber, the corresponding exposure metric values, and the average response weighted index (RWI) for the response of test fish are in Table 3.1.

*Holding the  $SEL_{cum}$  steady was done to examine the  $SEL_{cum}$  sample space and to implement treatments that could be used to explore the validity of the equal energy hypothesis.*

### 3.2.1 Barotrauma related to $SEL_{cum}$

Barotrauma injuries ranged from *Mild* to *Mortal*, depending on the amount of energy in the exposure. Mild injuries were those with little if any physiological cost to the fish for example, hematoma on a fin. *Mortal* injuries were those with high physiological cost that could cause death, such as hemorrhaging of the heart. Examples of injuries are shown in Figure 3.2. The RWI for 1920 and 960 impulsive sounds exposures showed an increase in the extent of physical injury with an increase in  $SEL_{cum}$  severity (Figure 3.3). It was also found that as  $SEL_{ss}$  increased, RWI increased exponentially (Figure 3.4). As RWI increased there were increases in the number of injuries for each exposed fish and physiological impact of those injuries (Figure 3.5).

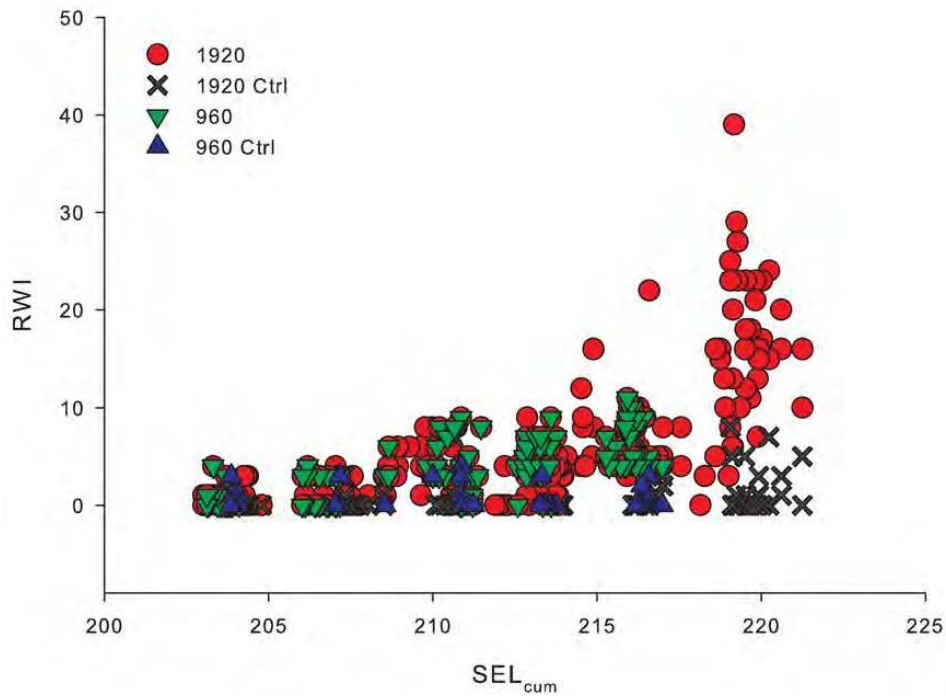

Figure 3.3. Individual RWI values by SEL<sub>cum</sub> for 1920 and 960 impulses and controls.

There were a few observations of barotrauma injuries in control fish. Injuries that appear in control are reflective of the sensitivity of the FIT model that was used in this study and of the health of the fish. A fish that is expressing a disease and then handled will often show injuries that would not be seen in a healthy fish. Of all documented barotrauma injuries, across all Treatments, 6% of the injuries were in control fish. Within the 6%, 61% of the injuries were Mild, 33% were Moderate, and 6% were Mortal. The three Mortal injuries were found in Treatment 1 (Figure 3.6).

Using ANCOVA, it was shown that the regression lines of the log transformed RWI ( $\ln(\text{RWI}+1)$ ) versus SEL<sub>cum</sub> ( $F_{1, 307} = 0.196, p = 0.658$ ) had the same slopes for both 960 and 1920 impulsive sound Treatment sets, but different intercepts ( $F_{1, 308} = 11.106, p = 0.001$ ) with the regression line for the 960 impulsive sound exposure lying above that for the 1920 impulsive sound exposure Treatments. A follow on regression analysis where Treatment 1 (SEL<sub>ss</sub> = 187, SEL<sub>cum</sub> = 220, number of impulses = 1920) was added to the 1920 impulsive sound data set did not change the linearity of the model fit to the data or the regression parameters (Figure 3.7).

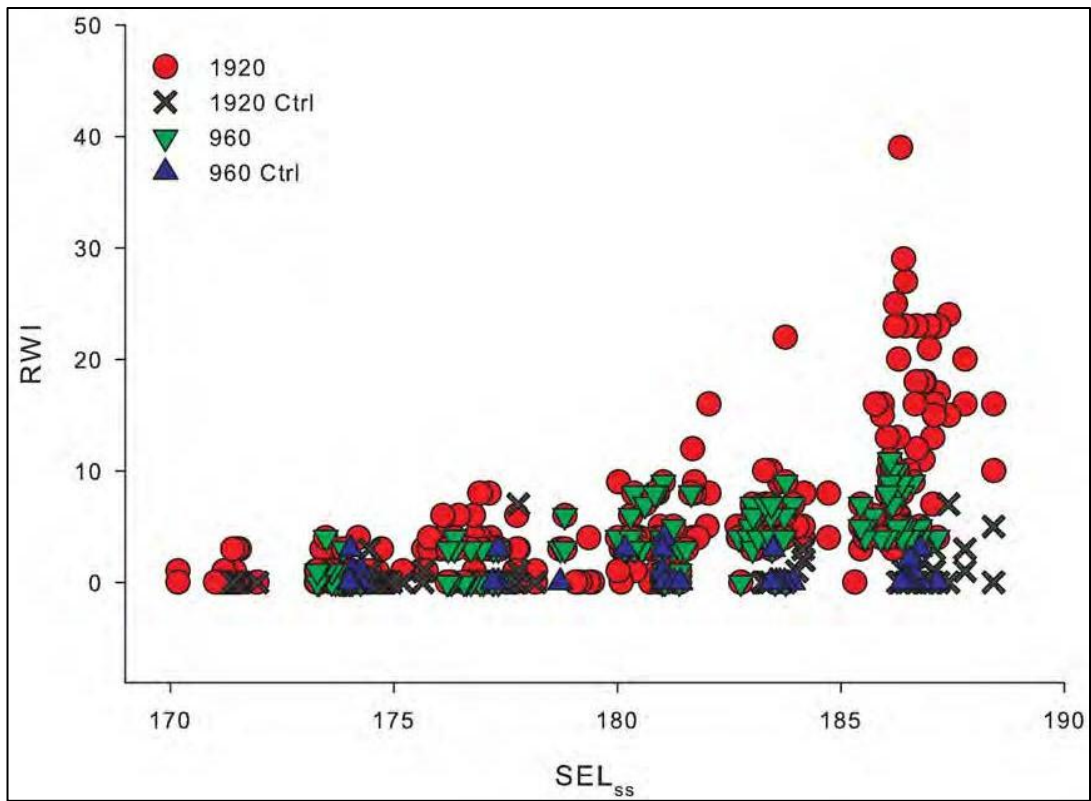

Figure 3.4. Individual RWI values by SEL<sub>ss</sub> for 1920 and 960 impulses and controls.



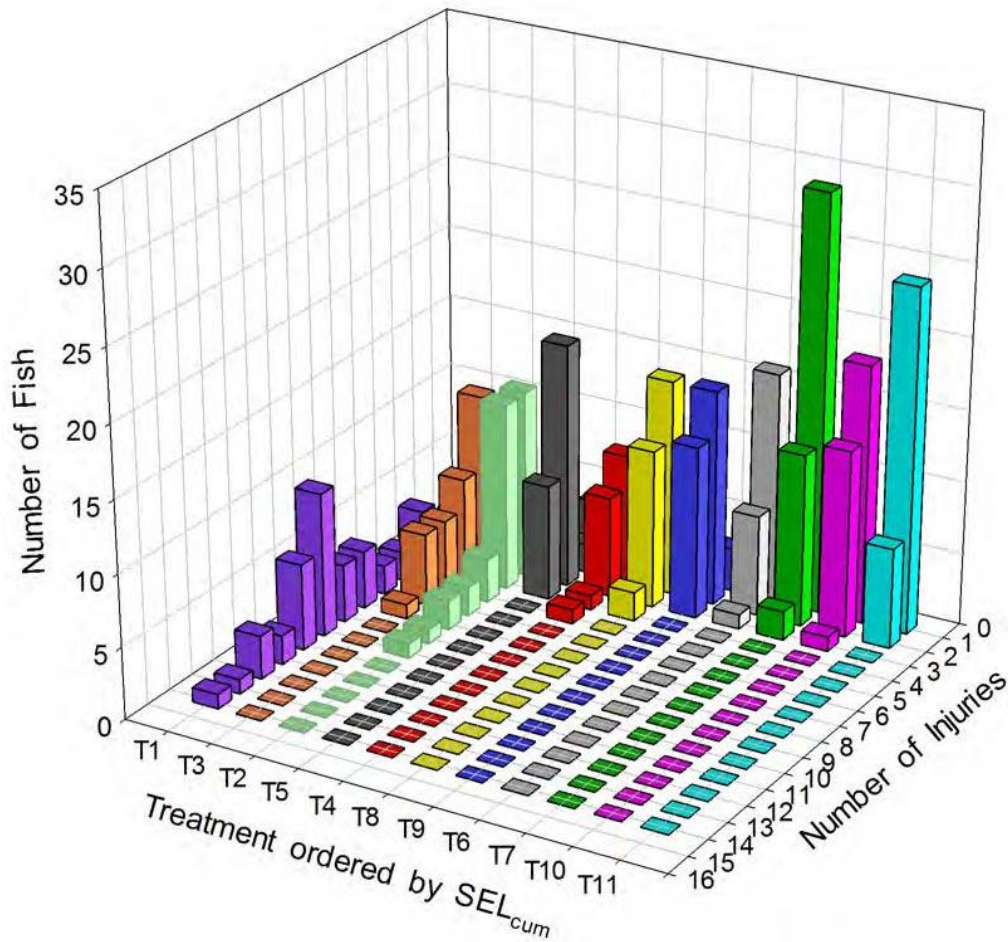

Figure 3.5. Frequency of barotrauma injury occurrence per fish. The number of test fish (z-axis) with number of unweighted-barotrauma injuries (x-axis) by each Treatment (y-axis) which is in order of  $SEL_{cum}$  values (see Table 3.1). For example, in the most severe exposure (Treatment 1 = T1, see Table 3.1 for each Treatments metrics), 1 fish had 13 injuries, and 10 fish had 8 injuries. Similarly, for the least severe exposure (T11), 6 fish had 1 injury, and 24 fish had 0 injuries.

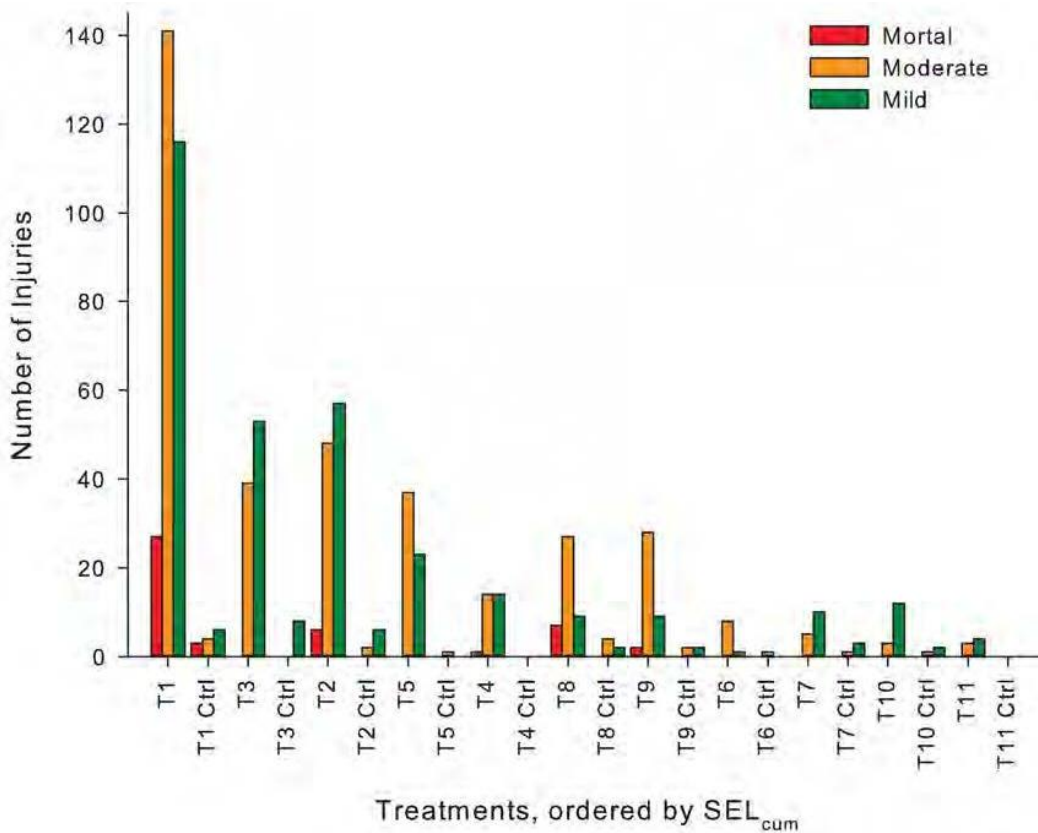

Figure 3.6. Number of injuries within each injury category. Within each Treatment bin is a representation of the number of injuries for each injury category of *Mortal*, *Moderate*, and *Mild*. The y-axis is number of injuries, x-axis is each treatment (exposure and control: ex., T1= Treatment 1 Exposure; T1 Ctrl = Treatment 1 Control).

The final regression model for the 1920 impulsive sound exposure data set was determined using the data for all Treatments 1-11. The log transformed RWI values showed that fish that experienced 960 impulsive sounds had statistically significant greater RWI values ( $F_{1, 352} = 6.03$ ;  $p = 0.0145$ ) for all Treatments, than fish exposed to 1920 impulsive sounds at the same values of  $SEL_{cum}$  (Figure 3.7). This is most likely the result of the higher  $SEL_{ss}$  for individual impulsive sounds that is required for the 960 Treatments to reach the same  $SEL_{cum}$  as 1920 impulsive sound Treatments. The results showed that the severity of fish injury is a function of the energy in  $SEL_{ss}$ ,  $SEL_{cum}$ , and the number of impulsive sounds.

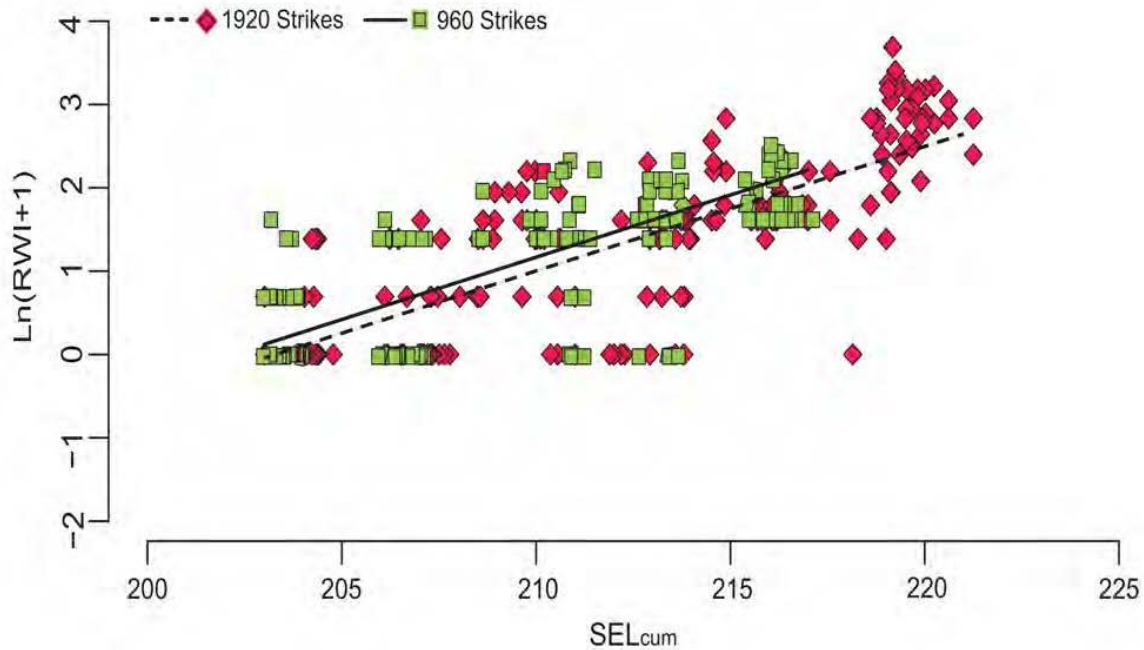

Figure 3.7. SEL<sub>cum</sub> vs. Ln (RWI+1) for all Treatments. Solid line shows predicted Ln(RWI+1) values for 960 strikes and dashed line for 1920 strikes. Green squares denote the 960 strikes and red diamonds denote the 1920 strikes.

### 3.2.2 Data Integration

The integrated study findings are in Figure 3.8 and show the relationship between the response of juvenile Chinook salmon, RWI, and the energy in SEL<sub>ss</sub>, SEL<sub>cum</sub> in an exposure consisting of a number of sequential impulsive sounds. The construction of Figure 3.8 is one contour plot overlain on a background contour plot. The background contour plot shows the sample space for the study. The background contour plot *x*- and *y*-axes are SEL<sub>ss</sub> and number of impulsive sounds, respectively, and the *z*-axis is SEL<sub>cum</sub>. The dashed contours show specific SEL<sub>cum</sub> values and are plotted on the multicolor background that provides additional information about the gradation in SEL<sub>cum</sub> over the plot surface.

The RWI values (*z*-axis) are represented in Figure 3.8 by the solid black contour lines. The *x*- and *y*-axes for the RWI contour plot are the same as those for the study sample space (background contour). The curvilinear contours were derived using the results of testing at 1920 and 960 over the range of SEL<sub>cum</sub> Treatment values and show the RWI values (1-10).

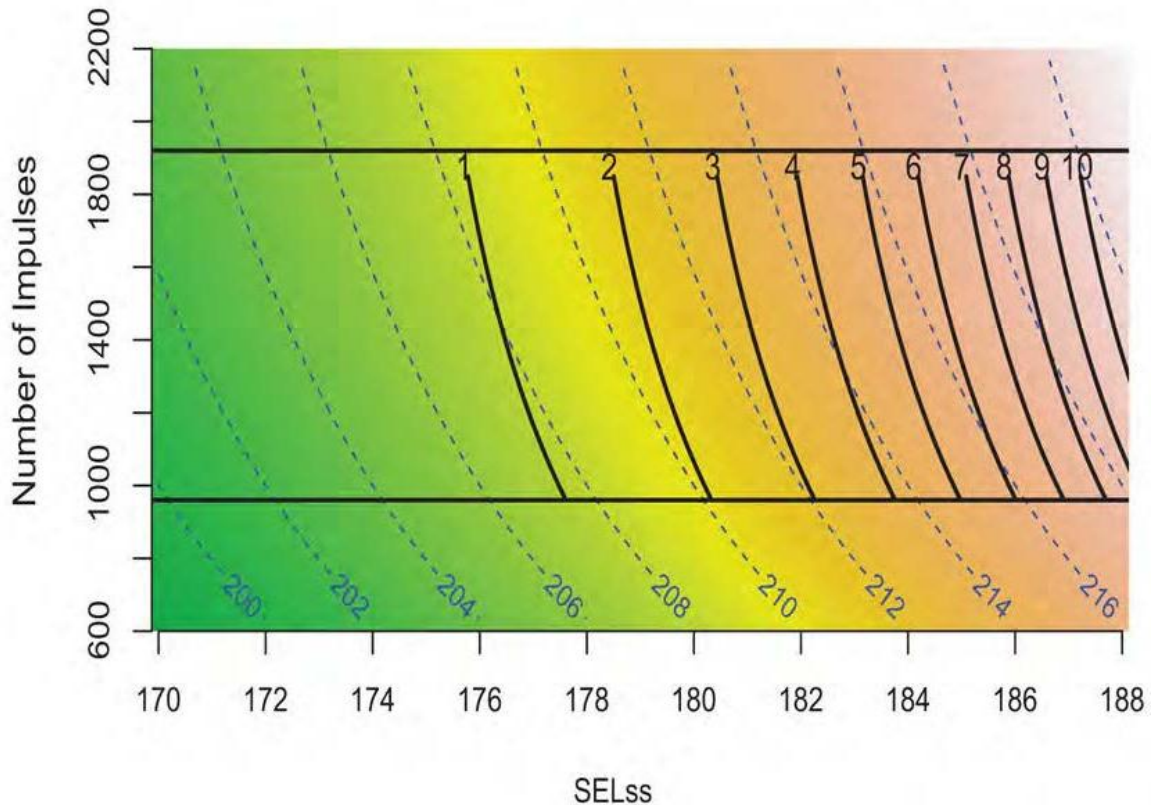

Figure 3.8. Contour plots of experimental space.

The background layer plots the  $SEL_{cum}$  contours (blue dashed lines represented by  $SEL_{cum} = SEL_{ss} + 10\log_{10}(\text{Number of strikes})$ ) by  $SEL_{ss}$ , and number of impulses within the Treatment range. The solid black lines labeled 1-10 are a contour plot of the log transformed RWI which illustrates value increases as  $SEL_{ss}$  increases; represented by  $RWI = \exp(-30.050 + 0.149 * SEL_{cum} - 0.000171 * \text{Number of strikes}) - 1$ . The upper black horizontal line indicates the 1920 strike-line, and the bottom black horizontal line indicates the 960 strike-line. Together, the plots show where the RWI contours fall over the  $SEL_{cum}$  range and  $SEL_{ss}$  range in relation to number of impulses.

### 3.3 Discussion

This is the first laboratory-based study to evaluate the effects of impulsive sounds, under plane-wave acoustic conditions, on neutrally buoyant juvenile fish. The relationship between barotrauma injury to fish and specific sound characteristics, such as number of impulsive sound exposures and sound energy level both  $SEL_{ss}$  and  $SEL_{cum}$  was systematically explored for onset of injury. The present study demonstrated that the severity of barotrauma, characterized using the FIT model and RWI units, is positively correlated with the energy in each impulsive sound ( $SEL_{ss}$ ), which can be summed over the total number of impulsive sounds generated by the number of pile strikes needed to drive a pile,  $SEL_{cum}$  (Figure 3.7). The highest energy exposures presented in this study, given over 960 and 1920 strikes, caused *Mortal* injuries that resulted in organ hemorrhages that are likely to result in mortality. Lower energy exposures caused fewer

barotrauma injuries, and these tended to be injuries found in the *Mild* category (Figure 3.6), such as fin hematoma, which has minimal physiological effects on the fish.

It is not possible to compare the work here with earlier studies of pile driving sound since those studies used caged fishes under conditions in which the investigators were unable to control the physiological state of the test fish at exposure or any aspects of sound presentation (e.g., number of impulsive sounds,  $SEL_{ss}$  or  $SEL_{cum}$ ). In addition, investigators of previous field studies often did not have adequate biological control groups (e.g., Nedwell et al. 2006; Abbott et al. 2005; Caltrans 2002, 2010a, b; Popper and Hastings 2009b; Ruggerone et al. 2008). While not clearly stated, the methodologies used in earlier studies suggest that the fish may not have been neutrally buoyant, thereby leaving the validity of the results open to question. It is imperative that future studies examining effects of any impulsive sound be conducted on animals that are determined to be neutrally buoyant, as was done in the present experiment.

### 3.3.1 Rejection of the Equal Energy Hypothesis for Impulsive Signals

The “equal energy hypothesis” (EEH) has been suggested as an applicable metric for mitigation of effects of impulsive sound exposure on fish (Stadler and Woodbury 2009; Woodbury and Stadler 2008). This hypothesis states that the same type and severity of injury would occur for the same total energy level of exposure ( $SEL_{cum}$ ), regardless of how the total energy was reached (e.g., a large number of low energy impulsive sounds or fewer high energy impulsive sounds) (Roberto et al 1985). More recently, studies have shown that this hypothesis is not valid for impulsive sound exposure in mammals (Hamernik and Davis 2003; Davis et al. 2009; Carlson et al. 2007), and data from the present experiment also rejects the EEH for fish. The data show the statistically significant difference ( $p = 0.0145$ ) between the 1920- and 960-strike regression lines (Figure 3.7). The difference in  $SEL_{ss}$  resulted in a difference in severity of injury despite the equality of  $SEL_{cum}$  for study Treatments. Thus, the  $SEL_{cum}$  alone is not sufficient to predict the risk of injury to exposed fish. When managing an activity that generates impulsive sound, the  $SEL_{cum}$  is an important variable to consider, along with the  $SEL_{ss}$  and the number of impulses.

### 3.3.2 Impulsive Sound Levels Relative to Injury Consequences

The RWI metric generated by the FIT model allowed for the identification of injury thresholds from impulsive sound exposure, and to define the onset of injury as it relates to impulsive sound (Halvorsen et al. 2011). The chance of survival for fishes injured by exposure to impulsive sound depends on the cumulative effect of barotrauma injuries on the physiological function of the fish. The *Mortal* injuries have a clear impact on physiological function such as damage to vital organs. *Moderate* injuries would require considerable opportunity for recovery that, under most circumstances, would be unavailable to the fish (e.g., predator free refuge, ideal flow rates, easily accessed nutrition rich foraging). The *Mild* injuries likely would not affect vital life functions nor swimming performance though physiological costs of healing may still be incurred. The *Mild* injuries singularly or in combination would be unlikely to reduce physiological function or affect the individual’s behavior. Therefore, *Mild* injuries were quantified as below the threshold of effects or as injuries that would have only minor physiological or behavioral cost to the fish, although this needs to be tested. A RWI value of 1 or

2 can only occur if a fish has 1 or 2 *Mild* injuries. A RWI value of 3, occurs with one moderate injury or three *Mild* injuries and thus the physiological functioning on some level would be impaired, and consequently fish survival probability starts to decline. The threshold for injury should consider the severity of injury, the category of injury, and the number of incurred injuries (see Figure 3.6). All these variables are taken into account by the FIT model and the RWI metric.

A RWI value of 2 is suggested to be used to identify the impulsive sound exposure criteria at the threshold of physical injury to juvenile Chinook salmon that, if exceeded, may likely result in physiological function and/or behavioral changes that will impact the survival of the exposed fish. Due to differences among species, life stages, and water quality, this recommendation applies to juvenile Chinook salmon, average length of 103 SL mm and an average wet weight of 11.8 g. A RWI of 2 could be carefully extrapolated to include other fish within the salmonid family of similar size. It is unclear at this time whether other species of fish would show the same injury response to impulsive sound exposure as the juvenile Chinook salmon used in this study.

### **3.3.3 Application of RWI**

The integrated contour plot (Figure 3.8) can be used to estimate the exposure conditions corresponding to a particular RWI level of interest or conversely, a RWI can be estimated from a particular set of exposure conditions within the bounds of the data for this study. For example, a RWI of 2 would be achieved for an exposure to 960 impulsive sounds when  $SEL_{ss}$  is 180 dB, yielding a  $SEL_{cum}$  of 210 dB, and for an exposure to 1920 impulsive sounds when  $SEL_{ss}$  is 177 dB yielding a  $SEL_{cum}$  value of 210 dB. By plotting the  $SEL_{cum}$  and RWI contour plots together onto one graph their relationship to each other as well as their relationship to  $SEL_{ss}$  and number of strikes become apparent. While complex, it links a common metric used to manage the exposure of fish to impulsive sound,  $SEL_{cum}$ , through its constituent parts,  $SEL_{ss}$  and number of impulsive sounds, along with the physical injury response variable, RWI.

The most important sound variables to which fish were exposed were the  $SEL_{ss}$  and the number of strikes in the case where each pile strike resulted in an impulsive sound with the same energy. These two variables can be used to control activities that generate impulsive sounds, either through management of the energy applied to a pile during each strike or by implementation of mitigating and monitoring actions. This study focused on impulsive sounds and it is reasonable to conclude that these sound level metrics could be extrapolated to other impulsive sounds, such as those generated by seismic exploration.

### **3.3.4 Implications of Results with Change in Depth**

The experiments described here were performed at absolute pressures equivalent to water surface (1 Atm). However, fish exposed to impulsive sounds in the wild are more likely to occupy greater depths, and could potentially change depth during activity generating impulsive sounds. Thus, the question arises as to the applicability of these results to fish at different depths.

Depth is a variable that may change the barotrauma injuries in fishes from impulsive sounds in deep water. Studies on the effects of rapid decompression on fishes have shown that the magnitude of the ratio of pressure to which fishes are acclimated and the pressure at which fishes

are exposed is proportional to the severity of barotrauma injury (Brown et al. 2009). If this ratio extends to pile driving and seismic impulsive sounds, it would introduce depth as another variable into the assessment of the effects of these sounds. The result would be a rapid decrease in the severity of exposure and biological response from relatively small increases in depth, given that the static pressure in water increases by about 100 kPa per 10 m of depth. Research is needed to determine if the relationship between acclimation- and exposure-pressures, and if response severity is the same for impulsive sound exposure as it is for rapid decompression.

### **3.3.5 Conclusion**

The study's experimental strategy was to determine the relationship between  $SEL_{ss}$ ,  $SEL_{cum}$ , number of strikes, and response to exposure. The principal result is that estimation of exposure conditions to impulsive sound can be used to manage the risk of physical injury to exposed juvenile Chinook salmon for any selected RWI value. The research results reported here start with a selected level of biological response that protects individuals in an exposed area from injuries that affect performance and/or energetics. The selected biological response level and the results of this study can be used to identify a level of exposure to assure protection of the fishes of concern.

The consequence of these findings is that the severity of injury to fish exposed to impulsive sound cannot be predicted from the  $SEL_{cum}$  alone in an exposure consisting of many impulsive events and must consider the energy in the individual impulsive sounds ( $SEL_{ss}$ ) as well the number of impulses that constitute the exposure. The importance of this combination of metrics is made clear for a RWI of 2 as the threshold for onset of injury. A RWI of 2 is reached by an exposure to 960 impulsive sounds when  $SEL_{ss}$  is 180 dB, deriving a  $SEL_{cum}$  of 210 dB or by an exposure to 1920 impulsive sounds when  $SEL_{ss}$  is 177 dB, yielding a  $SEL_{cum}$  of 210 dB.

## 4.0 Study 2: Recovery of Chinook Salmon

With permission from PLoS ONE, Section 4 is taken verbatim from *Casper, B. C., Popper, A. N., Matthews, F., Carlson, T. J., and Halvorsen, M. B. (2012). Recovery of barotrauma injuries in Chinook salmon, *Oncorhynchus tshawytscha* from exposure to pile driving sound. PLoS ONE, 7(6): e39593. doi:10.1371/journal.pone.0039593.*

### 4.1 Background

While establishing the threshold for injury onset, as discussed in the experiment described in Section 3, an important question arose as to whether fish would be able to recover from barotrauma injuries, or if some of these injuries would result in delayed mortality. Thus, a study of delayed mortality (or recovery) would provide insight into whether exposure to pile driving sounds could result in delayed onset injuries. With this in mind, this experiment examined the recovery of juvenile Chinook salmon from injuries sustained at two different SEL<sub>cum</sub> levels of pile driving. Evaluation of recovery was accomplished by sampling at four time points following exposure to document injuries and injury recovery response.

### 4.2 Methods

#### 4.2.1 Study Fish

Fish used in this study were juvenile Chinook salmon ( $99.4 \pm 8.49$  mm SL and  $10.1 \pm 3.24$  g), obtained from Pacific Northwest National Laboratory from the Priest Rapids Hatchery in Mattawa, Washington. Fish maintenance was as described in Sections 2 and 3.

#### 4.2.2 Fish exposure

Exposure to sounds was performed precisely as described in Sections 2 and 3.1. Four fish were placed in the HICI-FT and when the treatment (exposure or control) was completed, the fish were removed from the chamber. One fish was immediately necropsied for barotrauma assessment and the other three were returned to tanks for recovery periods of 2, 5, or 10 days for post-exposure assessment. Those three fish's feeding and swimming behaviors were observed and at 2, 5, and 10 days post-exposure, one fish was randomly selected for necropsy. Feeding behavior was documented by noting which fish were eating food pellets at all feeding periods, while swimming behavior was documented as swimming throughout the tank in a manner similar to behavior prior to exposure rather than sitting on the bottom or obvious labored swimming movements.

Two exposure paradigms were used for this study: Exposure 1 presented 960 strikes at a level of 217 dB re  $1 \mu\text{Pa}^2 \cdot \text{s}$  SEL<sub>cum</sub>, using 187 dB re  $1 \mu\text{Pa}^2 \cdot \text{s}$  SEL<sub>ss</sub>; Exposure 2 presented 960 strikes at a level of 210 dB re  $1 \mu\text{Pa}^2 \cdot \text{s}$  SEL<sub>cum</sub> using 180 dB re  $1 \mu\text{Pa}^2 \cdot \text{s}$  SEL<sub>ss</sub>. As the equal energy hypothesis was demonstrated to be false by Halvorsen et al. 2012 (Section 3.1) they reported that SEL<sub>cum</sub> alone is not sufficient to predict the risk of injury to fish exposed to impulsive sound, therefore it is important that all three metrics are reported together. From here



forward, the study will refer to Exposure 1 or Exposure 2 to simplify the reference to the exposure paradigms.

A total of 175 fish were exposed and 53 were used as controls and subject to the identical process as exposed fish but without the pile driving sound. The two exposure parameters were selected because the lower level (Exposure 2) was at the threshold for physical injury identified in Section 3 and the higher level (Exposure 1) presented about four times as much energy.

#### **4.2.3 Evaluation of barotrauma injuries and recovery**

Evaluation of barotrauma and recovery was done as described in Sections 2 and 3.1.

All necropsies were conducted “blind,” so that the investigator performing the dissections had no knowledge of whether each fish was an exposed sample or a control. For necropsy, fish were euthanized in a buffered MS-222 solution and examined for external signs of barotrauma (e.g. damage to eyes, fins, gills) utilizing methodology from previous Chinook salmon (Halvorsen et al. 2011, Stephenson et al. 2010). Each potential injury was noted as present or not (for a detailed list of all potential external and internal barotrauma injuries see Halvorsen et al. (2011)). Following the external assessment, fish were assessed internally. After the more ventral internal organs (e.g. stomach, intestines) were examined for injury they were carefully moved aside to examine deeper organs and tissues (e.g., swim bladder and kidney).

#### **4.2.4 Statistical Analysis**

Two-way ANOVA tests with Bonferroni correction on the multiple comparisons (SigmaPlot 11, SYSTAT Software, Inc.) were used to evaluate any differences between Exposure 1 and 2 and post exposure days in terms of both injury index values (RWI, as described in Section 3.1.4) as well as number of injuries observed. All statistical information is displayed in Table 4.1. analyses.

### **4.3 Results**

None of the fish in Exposure 1 or 2 died from barotrauma injuries out to 10 days post-exposure. Fish evaluated immediately (day 0) showed a wide range of injuries (Figure 4.1) that were similar to those reported in Section 3. Observed injuries most commonly included bruising of organs, while hemorrhaging of various tissues were observed much less frequently (Figure 4.2A-C). It should be noted that even with the presence of these injuries, the sound exposed fish were still able to obtain and digest fish food pellets as well as display normal swimming behaviors post exposure.

Table 4.1. Summary of statistical analyses between various exposure groups

<b>Variables Being Compared (E=Exposure)</b>	<b>Test</b>	<b>F Value</b>	<b>p Value</b>
Number of injuries observed between E1 and E2	ANOVA	$F_{1, 167} = 10.129$	$p < 0.001$
Injury Index Value between E1 and E2	ANOVA	$F_{1, 3} = 17.466$	$p = 0.025$
Number of injuries observed on Day 0 post exposure between E1 and E2	ANOVA	$F_{3, 167} = 7.650$	$p < 0.001$
Number of injuries observed on Day 2 post exposure between E1 and E2	ANOVA	$F_{3, 167} = 6.862$	$p < 0.001$
Number of injuries observed on Day 5 post exposure between E1 and E2	ANOVA	$F_{3, 167} = 2.621$	$p = 0.045$
Number of injuries observed on Day 10 post exposure between E1 and E2	ANOVA	$F_{3, 167} = 3.271$	$p = 0.036$
Number of injuries observed between Day 0 and Day 2 post exposure within E1	ANOVA	$F_{3, 167} = 0.404$	$p > 0.05$
Number of injuries observed between Day 0 and Day 5 post exposure within E1	ANOVA	$F_{3, 167} = 3.704$	$p = 0.008$
Number of injuries observed between Day 0 and Day 10 post exposure within E1	ANOVA	$F_{3, 167} = 5.035$	$p < 0.001$
Number of injuries observed between Day 2 and Day 5 post exposure within E1	ANOVA	$F_{3, 167} = 3.443$	$p = 0.040$
Number of injuries observed between Day 2 and Day 10 post exposure within E1	ANOVA	$F_{3, 167} = 4.424$	$p < 0.001$
Number of injuries observed between Day 5 and Day 10 post exposure within E1	ANOVA	$F_{3, 167} = 1.348$	$p > 0.05$
Number of injuries observed between Day 0 and Day 2 post exposure within E2	ANOVA	$F_{3, 167} = 0.115$	$p > 0.05$
Number of injuries observed between Day 0 and Day 5 post exposure within E2	ANOVA	$F_{3, 167} = 1.056$	$p > 0.05$
Number of injuries observed between Day 0 and Day 10 post exposure within E2	ANOVA	$F_{3, 167} = 1.023$	$p > 0.05$
Number of injuries observed between Day 2 and Day 5 post exposure within E2	ANOVA	$F_{3, 167} = 1.145$	$p > 0.05$
Number of injuries observed between Day 2 and Day 10 post exposure within E2	ANOVA	$F_{3, 167} = 0.891$	$p > 0.05$
Number of injuries observed between Day 5 and Day 10 post exposure within E2	ANOVA	$F_{3, 167} = 2.013$	$p > 0.05$

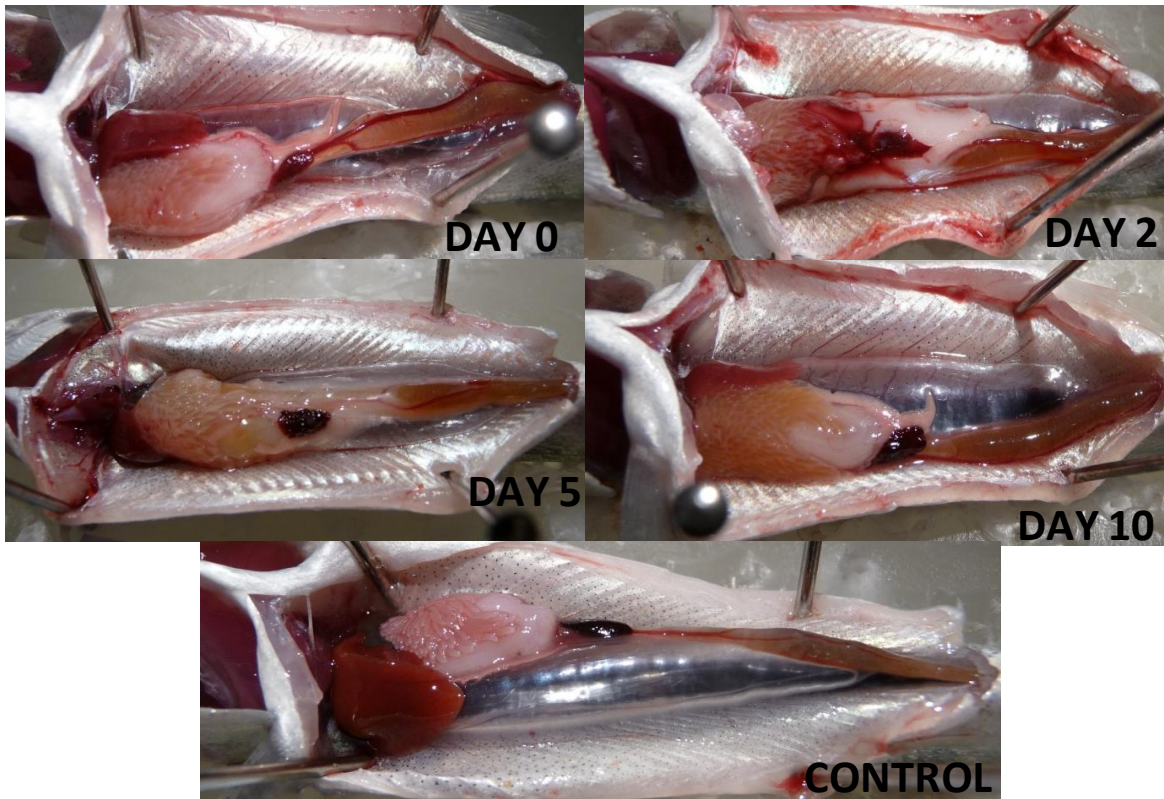
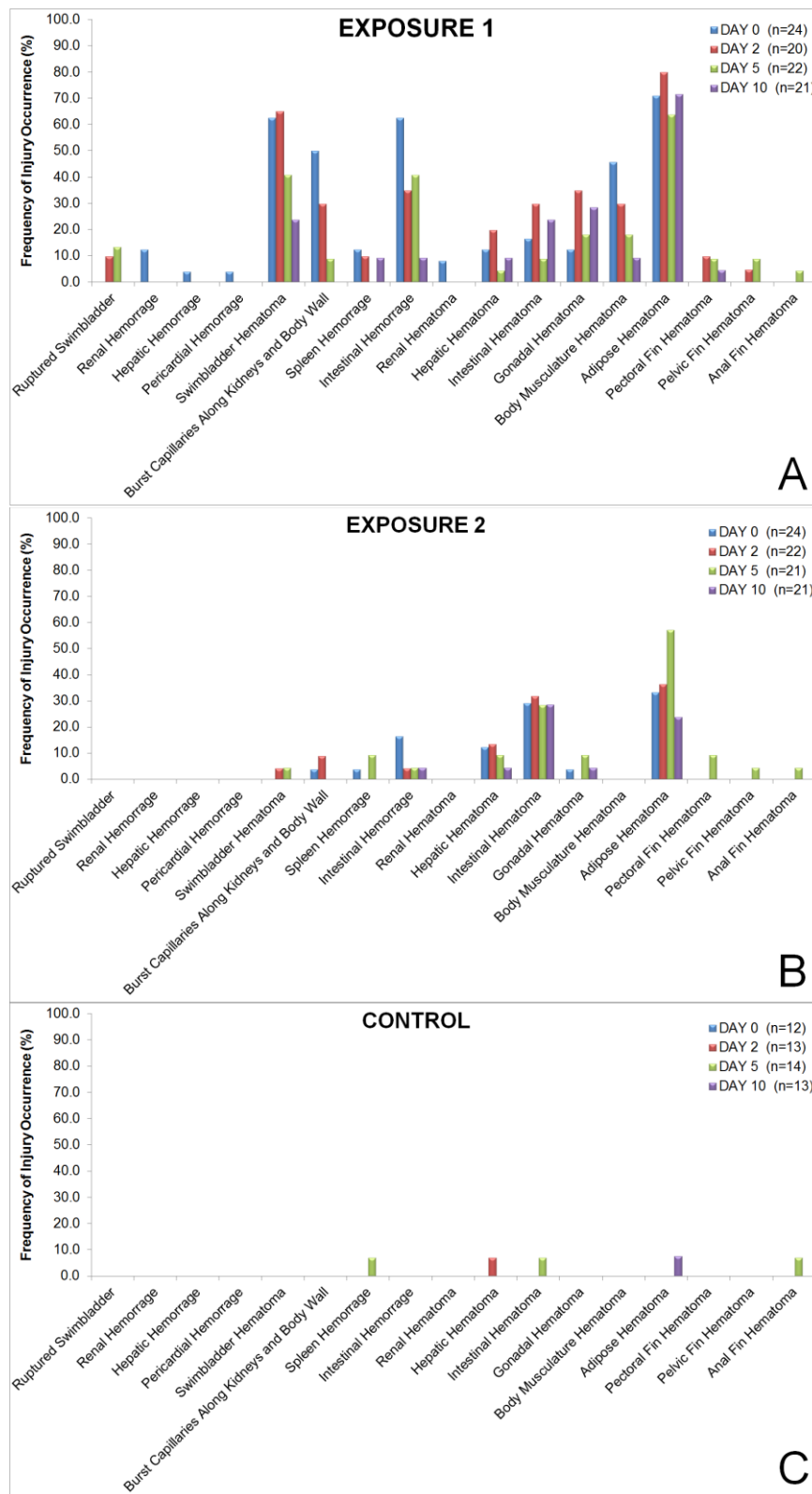

Figure 4.1. Photos of example injuries.

Ventral view of Chinook salmon, for Exposure 1 with recovery periods of 0, 2, 5, and 10 days post-exposure as well as an example of a control fish. Day 0 displays hematomas of the swim bladder, liver, and adipose tissue, as well as hemorrhaging of the intestine. Day 2 displays hemorrhaging of the spleen and hematomas of the intestine and adipose tissue. Day 5 displays a hematoma of the intestine. Day 10 displays a fish with no visible injuries, though mottling of the spleen (raspberry appearance) can be observed which was present in most fish that were exposed to sound pile driving sounds, and not usually present in control fish. The anterior ends of all fish are orientated to the left.

Figure 4.2. The frequency of occurrence of injuries from Exposure 1, 2, and controls.

Frequency of occurrence of injuries observed in Chinook salmon for Exposure 1(A), Exposure 2 (B), and control (C) at each of the four sample times post exposure. For a more detailed analysis of the individual injuries and their physiological significance please refer to Halvorsen et al. (2011).



A higher number of injuries were observed in fish in Exposure 1 than in Exposure 2 (Table 4.1 and Figure 4.3). Fish in Exposure 1 commonly exhibited swim bladder hematomas, burst capillaries, intestinal hemorrhages and hematomas, and hematomas of the gonads, adipose tissue, and body musculature, while fish in Exposure 2 generally displayed only intestinal and adipose hematomas (Figure 4.2). As a result, fish in Exposure 1 had a significantly higher injury index value than fish from Exposure 2 (Table 4.1 and Figure 4.4). There were significant differences in the number of injuries observed per fish for each day post-exposure between Exposure 1 and 2 (Table 4.1 and Figure 4.3).

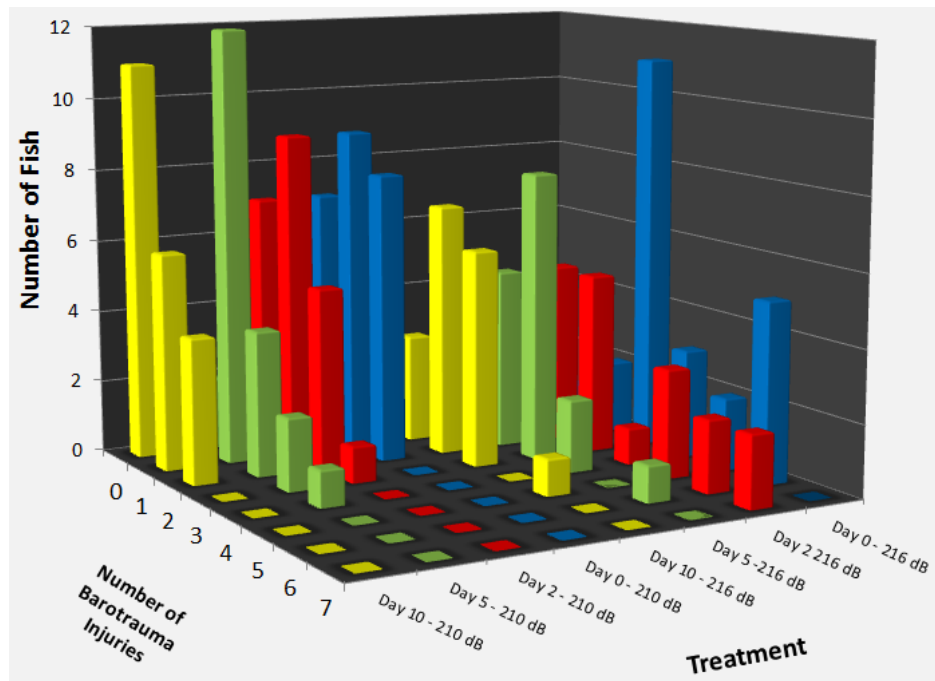

Figure 4.3. Number of observed injuries.

Injuries that were observed in Chinook salmon for Exposure 1 and 2 as well as the different days post-exposure. There were a higher number of injuries observed at Exposure 1 at 216 dB versus Exposure 2 at 210 dB. Numbers of injuries observed were higher at the earlier days post-exposure for Exposure 1 compared with the later days indicating that healing was occurring.

#### 4.3.1 Comparisons Between Days Within Each Treatment

Chinook salmon in Exposure 1 showed higher frequencies of occurrence of injuries observed at day 0 and at day 2 post-exposure (Figure 4.3 and Table 4.1). There was, however, no significant difference between the number of injuries when comparing days 0 and 2 or when comparing days 5 and 10 (Table 4.1). By day 10 there was an average of only 1.90 injuries observed per fish. While there was no significant difference in the injury index values among the different days post-exposure (Table 4.1), visual examination of Figure 4.4 shows a drop of 120 injury index points between days 0 and 2 versus days 5 and 10, which implies that recovery of

most injuries likely began after day 2. Recovery was further indicated by the decrease in the frequency of occurrence of each injury across the sample days as shown in Figure 4.2.

Fish subject to Exposure 2 averaged between 0.5 and 1.5 injuries per fish (Figure 4.3), and of the 81 fish tested 27 (33%) incurred no injuries. The number of injuries observed per fish did not differ significantly from control fish at any days post exposure ( $F_{1,67}=10.109$ ,  $p<0.001$ ). The average injury index values at each day post-exposure were also low, with values on all days lower than those observed at any day in Exposure 1 fish (Figure 4.4).

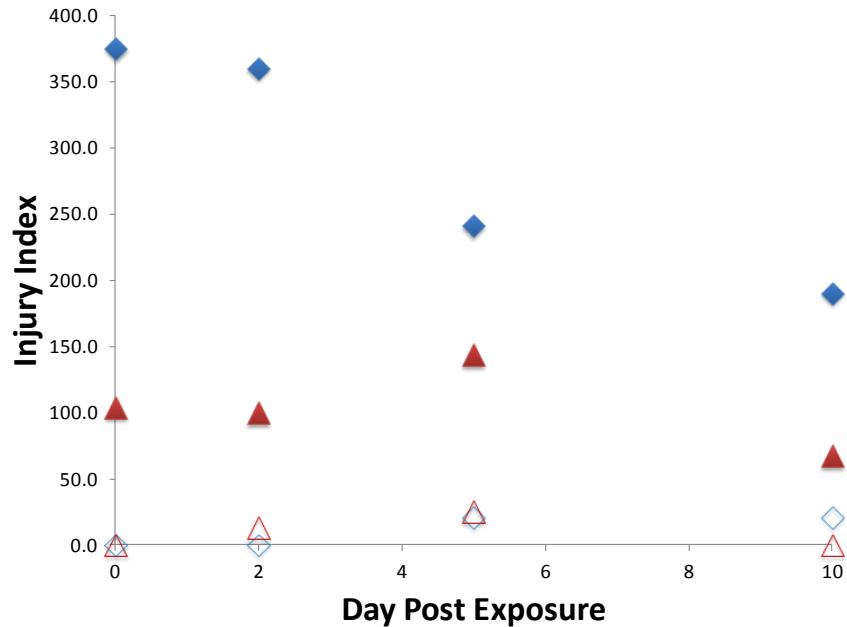

Figure 4.4. Injury index values for Chinook salmon.

The injury index values for Exposure 1 and 2 to which Chinook salmon were exposed. There was a significant decrease in RWI scores from day 2 to day 5 in Exposure 1 fish (solid blue diamonds), suggesting that this is when healing is beginning to occur. There were no differences between days 5 and 10, implying that after initial healing of more serious injuries occurs, it then may take longer for minor injuries such as hematomas to heal. There was no significant difference between days 0 through 10 for fish in Exposure 2 (solid red triangles) and each day was not significantly different than controls (open blue diamond for Exposure 1 and open red triangle for Exposure 2).

## 4.4 Discussion

This study followed upon previous research on pile driving sound effects on Chinook salmon described in Section 3, which established the onset of barotrauma injuries from pile driving as 210 dB re 1  $\mu\text{Pa}^2 \cdot \text{s}$   $\text{SEL}_{\text{cum}}$  derived from 180 dB re 1  $\mu\text{Pa}^2 \cdot \text{s}$   $\text{SEL}_{\text{ss}}$  with 960 impulsive signals. This study independently replicated the onset level of barotrauma injury reported earlier and investigated the potential for injury recovery incurred from pile driving exposure up to 10 days post-exposure in a laboratory setting.

Chinook salmon in Exposure 1, showed a decrease in the number of injuries observed per fish (Figure 4.3) as well as the number of *Mortal* and *Moderate* injuries observed (Figure 4.2) suggesting some level of recovery in fish examined by days 5 and 10 post-exposure. This is further supported by observing a general trend (Figure 4.4) of decreasing injury index values from days 0 and 2 to days 5 and 10. The number of injuries observed were significantly higher at day 0 and 2 and there was a wide range of injuries observed from *Mild* to *Mortal* (Figure 4.2) based on the established injury classification system (Stephenson et al. 2010). Days 0 and 2 were not statistically different from one another in terms of injury index, suggesting that the healing processes might begin after day 2. As the amount of time after exposure increased, the number of observed injuries significantly decreased from day 2 to day 5, as did the injury class of the remaining injuries. There was no significant difference in the number of injuries observed between days 5 and 10, leading to the suggestion that hematomas, the primary observed injuries at day 10, need more time to heal.

On average, Chinook salmon in Exposure 2 had fewer than 1.5 injuries per fish at any of the days post-exposure, and only *Moderate* and *Mild* injuries were observed. Furthermore, the number of injuries observed in exposed fish was not significantly different from control fish, and all four days had lower injury index values than those observed in Exposure 1 fish.

There were several instances of injuries appearing in samples at days 2 and 5 post-exposure that were not observed in the day 0 sample (Figure 4.2). These injuries include the presence of ruptured swim bladder, hepatic, intestinal, and gonadal hematomas from Exposure 1 while injuries from Exposure 2 included bruised swim bladder, burst capillaries, spleen hemorrhage, and gonadal hematomas. The explanation for the observation of injuries on day 5 that were not observed at day 0 or 2 is likely because the study was cross sectional and not longitudinal in design and fish were sacrificed to ascertain the internal physical injury. In cross-sectional studies it is possible to observe responses that have an overall low probability of occurring and longer recovery time requirements during later post-exposure sampling periods. Such observations occur when a fish experiences a low probability injury at exposure but is randomly sampled for examination at a late post-exposure date.

## 4.5 Interpretation of These Results

These results provide additional information to aid development of guidelines for the protection of aquatic animals from pile driving and other anthropogenic noise sources. The results from this study and its predecessor described in Section 3 show that juvenile Chinook salmon can be exposed to pile driving sounds substantially louder than the current industry guidelines of 187 dB re 1  $\mu\text{Pa}^2\cdot\text{s}$  SEL<sub>cum</sub> (Woodbury and Stadler 2008; Stadler and Woodbury 2009) and are either not injured or sustain injuries that are not fatal and appear to be recoverable in a laboratory setting. It should be acknowledged that these results are specifically for juvenile Chinook salmon and that it is possible that adult Chinook salmon and other species of salmonids could respond differently to these pile driving stimuli (Carlson et al. 2007).

This study was conducted in a laboratory environment in which sound exposure levels and numbers of pile strikes were controlled. The recovery encountered in this study does not necessarily mean that fish in the wild would recover in the same manner since fish in the wild have to deal with numerous factors (e.g., having to seek food and avoid predators) that are not

encountered in the lab. At the same time, it is likely that the level and duration of exposure of the lab animals was substantially greater than would be encountered by fish in the wild since wild animals may potentially move away from the locale of pile driving before the onset of any physiological effects. Moreover, if a wild fish does show an effect from pile driving exposure the results reported here show that recovery may be possible if the fish is not subject to adverse conditions.



## 5.0 Study 3: Effects of Sound on Hogchoker, Nile Tilapia, and Lake Sturgeon

With permission from Proceedings of the Royal Society B, Section 4 is taken verbatim from Halvorsen, M. B., Casper, B. C., Matthews, F., Carlson, T. J., and Popper, A. N. (2012). *Effects of exposure to pile driving sounds on the lake sturgeon, Nile tilapia, and hogchoker. Proceedings of the Royal Society B*, rspb20121544..

### 5.1 Background

Anthropogenic noise has been established as a potential concern related to the health and survival of world-wide fish stocks (Popper and Hawkins 2012). Among the types of potentially dangerous noise sources that could result in injury are shipping, sonar, seismic surveying, and construction sounds. However, there are very few quantitative data on the physiological effects of these sounds on fishes (Popper and Hastings 2009a, b; Popper and Hawkins 2012).

Recent studies (Bolle et al. 2012; Casper et al. 2012a; Halvorsen et al. 2011, 2012a) have evaluated the effects of impulsive pile driving on fishes using methods that enable investigators to bring high intensity sound sources into the laboratory for evaluation of effects. Halvorsen *et al.* (Halvorsen et al. 2011, 2012) provided a scientific recommendation for the onset of injury threshold in juvenile Chinook salmon (*Oncorhynchus tshawytscha*, Salmonidae) at a cumulative SEL ( $SEL_{cum}$ ) of 210 dB re  $1 \mu Pa^2 \cdot s$  derived from 960 pile strikes, each having a single strike SEL ( $SEL_{ss}$ ) of 180 dB re  $1 \mu Pa^2 \cdot s$ . These results were further supported in an injury recovery study on the same species (Casper et al. 2012a). Moreover, Bolle et al. (2012) found no difference in mortality between control and exposed common sole (*Solea solea*, Solidae) larvae (including stage 3-4a larvae which had inflated swim bladders) at an  $SEL_{cum}$  of 206 dB re  $1 \mu Pa^2 \cdot s$  over 100 pile strikes and a single strike SEL ( $SEL_{ss}$ ) of 186 dB re  $1 \mu Pa^2 \cdot s$   $SEL_{ss}$ . While these initial studies provided data for understanding effects of pile driving on these two species of fishes, there is still too little information to be able to make generalized predictions and/or recommendations regarding what injuries to expect from other sizes of these species as well as anatomically and physiologically different species of fishes exposed to pile driving.

One key variable that could potentially alter the types and frequency of occurrence of injuries is the presence or absence of a swim bladder as well as the type of swim bladder (8). There are two general types of swim bladders in fishes: physoclistous and physostomous. The physostomous swim bladder (found in salmonids, sturgeons, and many of the more evolutionarily ancestral fishes) is connected to the gut via a pneumatic duct, thus allowing the fish to gulp air from the water surface or expel air to quickly adjust the volume of air within the swim bladder. The physoclistous swim bladder (found in many of the more recently evolved fish species including bass, perch, and rockfish) has a gas gland which provides gas exchange by diffusion between the swim bladder and blood. There are also many species of fishes such as flatfishes, gobies, and elasmobranchs that do not possess a swim bladder.

When a fish with a swim bladder is exposed to low frequency impulsive energies, including pile driving, the swim bladder acts like an air bubble that vibrates with sufficient magnitude to cause damage to tissues and organs within close proximity, as well as to the swim bladder itself

(Casper et al. 2012a; Halvorsen et al. 2011, 2012a). Therefore, it would seem likely that fishes with physostomous swim bladders could potentially expel air, thereby diminishing the tension on the swim bladder and decreasing damaging effects during exposure to impulsive sounds. In contrast, fishes with a physoclistous swim bladder are incapable of decreasing the volume of gases fast enough to avoid sustaining more severe injuries. Perhaps the least likely to yield damage would be fishes without a swim bladder.

This study presents a comparative analysis of response to pile driving stimuli in the lake sturgeon (*Acipenser fulvecens*, Acipenseridae), a species with a physostomous swim bladder; the Nile tilapia (*Oreochromis niloticus*, Cichlidae), a species with a physoclistous swim bladder; and the hogchoker (*Trinectes maculatus*, Achiridae) a flatfish without a swim bladder. While none of these species are currently known to be receiving high levels of exposure by anthropogenic sound sources, other species of sturgeon are listed under the Endangered Species Act in the U.S. and therefore are of particular concern with regard to effects of sounds from pile driving and other intense sounds, making the lake sturgeon a valuable proxy for understanding sound exposure.

Fishes in this study were exposed to several different SEL<sub>ss</sub> and SEL<sub>cum</sub> levels using the same High Intensity Controlled Impedance Fluid-filled wave Tube (HICI-FT) used by Halvorsen *et al.* (2011, 2012) and Casper *et al.* (2012a) to assess the frequency and types of injuries that occurred. The results not only provide some insight into the potential impacts of how physostomous vs. physoclistous swim bladders may impose damage on body tissues, but it also extends earlier work to provide a more generalized understanding of impulsive sound levels that may help determine the onset of tissue damage in fishes.

## 5.2 Methods

### (a) Fish Species Information

Nile tilapia ( $84.2 \pm 9.6$  mm SL and  $18.8 \pm 8.1$  g; approximately 6 months old) were obtained in April, 2011 from a breeding colony in the laboratory of Dr. Thomas Kocher of the Department of Biology at the University of Maryland. These fish were acclimated for a minimum of two weeks following transportation between laboratories before being used in experiments. The fish had their caudal fins clipped for identification during experiments.

Hogchokers ( $61.5 \pm 18.9$  mm SL and  $11.6 \pm 11.9$  g; ages ranged from juveniles to adults) were collected in July, 2011 using a bottom trawl in the Patuxent River, Calvert County, Maryland, USA and held at the Solomon's Island research laboratory until transportation to the University of Maryland. Due to difficulties in finding a suitable food source for these fish in the lab, acclimation time following arrival was only three days. Any fish that had external injuries due to being caught in the trawl were removed before experimentation. Individual hogchokers were easily identified through natural markings and so did not require a tail clip.

Lake sturgeon ( $65.7 \pm 5.2$  mm SL and  $1.6 \pm 0.4$  g; 3-4 months old) were obtained from the Wisconsin Department of Natural Resources Wild Rose Inland Hatchery (Wild Rose, WI) in August, 2011. These fish were acclimated for a minimum of two weeks following shipping from

the hatchery before being used in experiments. Due to the small size of the sturgeon fins, fin clipping was not used for identification.

In all cases, fish were maintained on a 14:10 light/dark cycle in 235 gallon round tanks. Fish that were scheduled to be used in experiments were not fed during the experimental week so the digestive system would be void of food during sound exposure since initial work with Chinook salmon showed that increased numbers of injuries were found in fish with food in their guts versus those without (personal obs. M. Halvorsen).

Experiments were conducted under supervision and approval of the Institutional Animal Care and Use Committee (IACUC) of the University of Maryland (protocol #R-09-23).

*(b) Pile driving exposure equipment and signal presentation*

Pile driving exposure was conducted using the HICI-FT. This device has a cylindrical holding chamber that is 45 cm long with a 25 cm internal diameter and 3.81 cm-thick stainless steel walls. Large shakers on either end of the chamber were used to create sounds that accurately reproduced the acoustic characteristics and sound levels of pile driving sounds under far-field plane wave acoustic conditions. For a detailed description of the equipment and its development see Halvorsen *et al.* (2011, 2012).

Signal generation and data acquisition for the HICI-FT are described in detail in Halvorsen *et al.* (2011, 2012). The pile driving sounds used in this study were field recordings at a depth of 5 m taken at a range of 10 m from a 76.2 cm steel shell pile (outer diameter) driven using a diesel hammer at the Eagle Harbor Maintenance Facility (MacGillivray and Racca 2005). Eight different recordings of pile driving strikes were normalized to the same SEL. Twelve repetitions of each of the 8 strikes generated a file of 96 strikes that were randomized each day using MATLAB (The MathWorks, Inc., Natick, Massachusetts). That file was repeated 10 times for a 960-strike presentation.

*(c) Fish exposure*

Four fish were allowed to swim freely in an acrylic chamber mounted around the opening of the HICI-FT exposure chamber for a 20 minute acclimation period. The fish were then allowed into the exposure chamber and the upper shaker/lid was sealed over the chamber opening. The acrylic chamber was drained and the HICI-FT rotated from the vertical position to the horizontal position for each exposure or control treatment.

Buoyancy was documented in all fishes as done in previous studies (Halvorsen *et al.* 2011, 2012). However, the hogchokers always sat on the bottom, the Nile tilapia always displayed neutral buoyancy, and the lake sturgeon always swam along the walls but were never observed to gulp air (or expel air) as was the case with the physostomous Chinook salmon (Halvorsen *et al.* 2011, 2012).

In total for these experiments, 125 Nile tilapia were exposed plus 32 controls, 57 hogchokers were exposed plus 10 controls, and 141 lake sturgeon were exposed plus 32 controls. Control fish were subject to the identical process as exposed fish but without the pile driving sound. Exposure sound levels for each species began with a SEL<sub>cum</sub> of 216 dB re 1  $\mu\text{Pa}^2\cdot\text{s}$ , derived from 960 pile strikes and 186 dB re 1  $\mu\text{Pa}^2\cdot\text{s}$  SEL<sub>ss</sub> (Treatment 1). The SEL<sub>cum</sub> for subsequent trials

was decreased in 3 dB steps for each treatment as summarized in Table 5.1. From here forward, the study will refer to Treatment 1 - 5 to simplify the reference to the exposure paradigms.

Table 5.1. List of treatment metrics

Treatment Name	SEL <sub>cum</sub>	SEL <sub>ss</sub>	# Pile Strikes	# Lake Sturgeon	# Nile Tilapia	# Hogchoker
Treatment 1	216 dB re 1 $\mu\text{Pa}^2\cdot\text{s}$	186 dB re 1 $\mu\text{Pa}^2\cdot\text{s}$	960	32 E/ 8 C	31 E/ 6 C	57 E/ 10 C
Treatment 2	213 dB re 1 $\mu\text{Pa}^2\cdot\text{s}$	183 dB re 1 $\mu\text{Pa}^2\cdot\text{s}$	960	28 E/ 8 C	38 E/ 10 C	N/A
Treatment 3	210 dB re 1 $\mu\text{Pa}^2\cdot\text{s}$	180 dB re 1 $\mu\text{Pa}^2\cdot\text{s}$	960	28 E/ 8 C	34 E/ 10 C	N/A
Treatment 4	207 dB re 1 $\mu\text{Pa}^2\cdot\text{s}$	177 dB re 1 $\mu\text{Pa}^2\cdot\text{s}$	960	24 E/ 8 C	30 E/ 6 C	N/A
Treatment 5	204 dB re 1 $\mu\text{Pa}^2\cdot\text{s}$	174 dB re 1 $\mu\text{Pa}^2\cdot\text{s}$	960	29 E/ 8 C	30 E/ 6 C	N/A
e= exposed; c= control						

Following each treatment, fish were euthanized in a buffered MS-222 solution, necropsied, and examined for external and internal signs of barotrauma (e.g., damage to eyes, fins, gills) utilizing methodology from previous Chinook salmon studies (Halvorsen et al. 2011, 2012; Stephenson et al. 2010). Each potential injury was noted as present or not (for a detailed list of all potential external and internal barotraumas injuries see Halvorsen et al. 2011).

*(d) Evaluation of barotrauma injuries*

Each observed injury was assessed and then assigned to weighted trauma categories (Halvorsen et al. 2011, 2012): *Mortal*, *Moderate*, or *Mild*. The *Mortal* trauma category, weighted 5, included injuries that were severe enough to lead to death. The *Moderate* trauma category, weighted 3, included injuries likely to have an adverse impact on fish health but might not lead directly to mortality. Finally, *Mild* trauma category, weighted 1, referred to injuries of minimal to no adverse physiological effects to fish. The weight assignments applied to each of the three trauma categories were based on the assessment of physiological significance that considered the influence of multiple injuries and inspection of data for the occurrence of injury combinations. The Response Weighted Index (RWI) is the sum of the presence of each injury multiplied by the trauma weight assigned to each injury type. The formula was:

$$\text{RWI} = \sum (\text{Injury} * \text{Weight}) \qquad \text{Equation 1}$$

*(e) Statistical Analysis*

A one-way ANOVA was used to evaluate injuries within fish species with two-way ANOVA used for evaluating injuries between fish species. A post hoc Tukey-test on the multiple comparisons (SigmaPlot 11, SYSTAT Software, Inc.) was used to evaluate any differences between species and treatments in terms of both RWI values as well as number of injuries observed. All statistical information is displayed in Tables 5.2 to 5.5

### 5.3 Results

None of the fishes died during the pile driving exposure within the HICI-FT. Also, at the loudest exposure paradigm, Treatment 1, there were no external or internal injuries observed in any of the hogchokers (Figure 5.1) thus, this species was not tested at any of the lower treatment levels. In the Nile tilapia (Figure 5.2), a variety of injuries were observed ranging from *Mortal* injuries such as ruptured swim bladders and renal hemorrhages to *Moderate* hematomas. In the lake sturgeon (Figure 5.3), injuries ranged between *Moderate* hematomas and *Mild* partially deflated swim bladders. There were no external injuries in any of the species tested.

Four different injuries were observed in the lake sturgeon (Figure 5.4) including hematomas on the swim bladder, kidney and intestine (all *Moderate* injuries), as well as partially deflated swim bladders (*Mild* injury). Injuries were most frequently observed in Treatments 1 and 2 (Figure 5.5). The level of injury (2.4 in Treatment 1 and 2.6 in Treatment 2) did not differ significantly from each other (Table 5.2). The frequency of injuries then dropped a statistically significant amount between Treatments 2 and 3 (mean of 1.1 injuries; Table 5.2).



Figure 5.1. Examples of internal anatomy in hogchoker. Control (a) and exposed (b) fish. There were no injuries observed in the organs for exposed or control fish. Organs visible within the pictures include liver (L), stomach (St), kidney (K), gall bladder (GB), intestine (In), and gonads (G). Both photos show the dorsal side of the fish with anterior to the right.

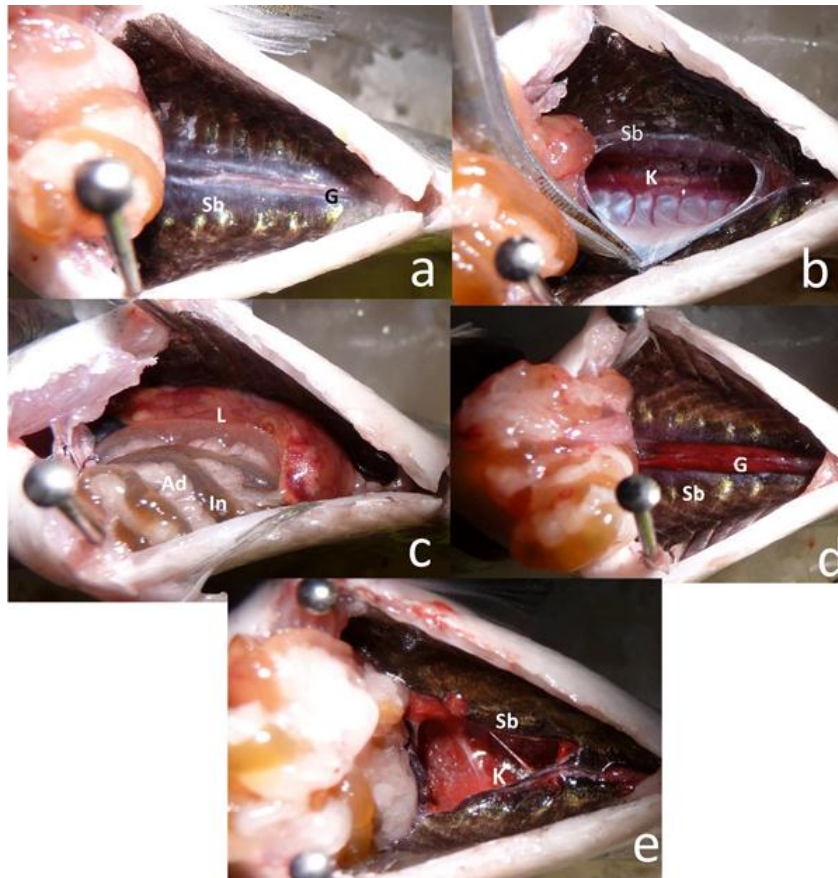

Figure 5.2. Examples of internal anatomy of the Nile tilapia. Control (a, b) and exposed (c, d, e) fish. In photo a, the internal organs have been pulled away to show a healthy swim bladder (Sb) and gonads (G) which are visible as clear, thin structures along the midline of the swim bladder. A healthy swim bladder has a white strip of tissue down the midline of the swim bladder (a bruised swim bladder has a dark red color down the midline). In photo b, the internal organs have been pulled away and the swim bladder has been cut open to show a healthy kidney (K). Photo c shows hepatic hematoma (i.e. bruising of the liver (L)). In photo d, the internal organs have been pulled away to reveal bruising of the gonads. Also note the lack of white tissue along the midline of the swim bladder which is a typical sign of swim bladder hematoma. In photo e, the internal organs have been pulled away and the swim bladder has been cut open to reveal renal hemorrhaging. All photos show ventral portion of body with anterior to the left. Other organs pictured: Intestine (In), Adipose tissue (Ad).



Figure 5.3. Examples of internal anatomy of the lake sturgeon. Control (a) and exposed (b, c) fish. Photo a shows a fully inflated, healthy swim bladder (Sb) and kidney (K) (visualized by the grey strip of tissue above the swim bladder). Photo b shows a partially deflated and bruised swim bladder. Photo c shows renal hematoma a (i.e. bruised kidney) (visualized by the reddening of the grey strip of tissue above the swim bladder). Other organs pictured: Intestine (In).

Table 5.2. Statistical analyses of number of injuries for sturgeon and tilapia.

Species	Number of Injuries	ANOVA	F Values	p Values
Lake Sturgeon	Treatment 1-5	ANOVA	$F_{4, 89} = 7.071$	$p < 0.001$
	Treatment 1 and 2	Post-hoc		$p = 0.807$
	Treatment 2 and 3	Post-hoc		$p < 0.001$
	Treatment 3 and 4	Post-hoc		$p = 0.550$
	Treatment 4 and 5	Post-hoc		$p = 0.162$
Nile Tilapia	Treatment 1-5	ANOVA	$F_{4, 123} = 9.330$	$p < 0.001$
	Treatment 1 and 2	Post-hoc		$p < 0.001$
	Treatment 2 and 3	Post-hoc		$p = 0.003$
	Treatment 3 and 4	Post-hoc		$p < 0.001$
	Treatment 4 and 5	Post-hoc		$p = 0.041$

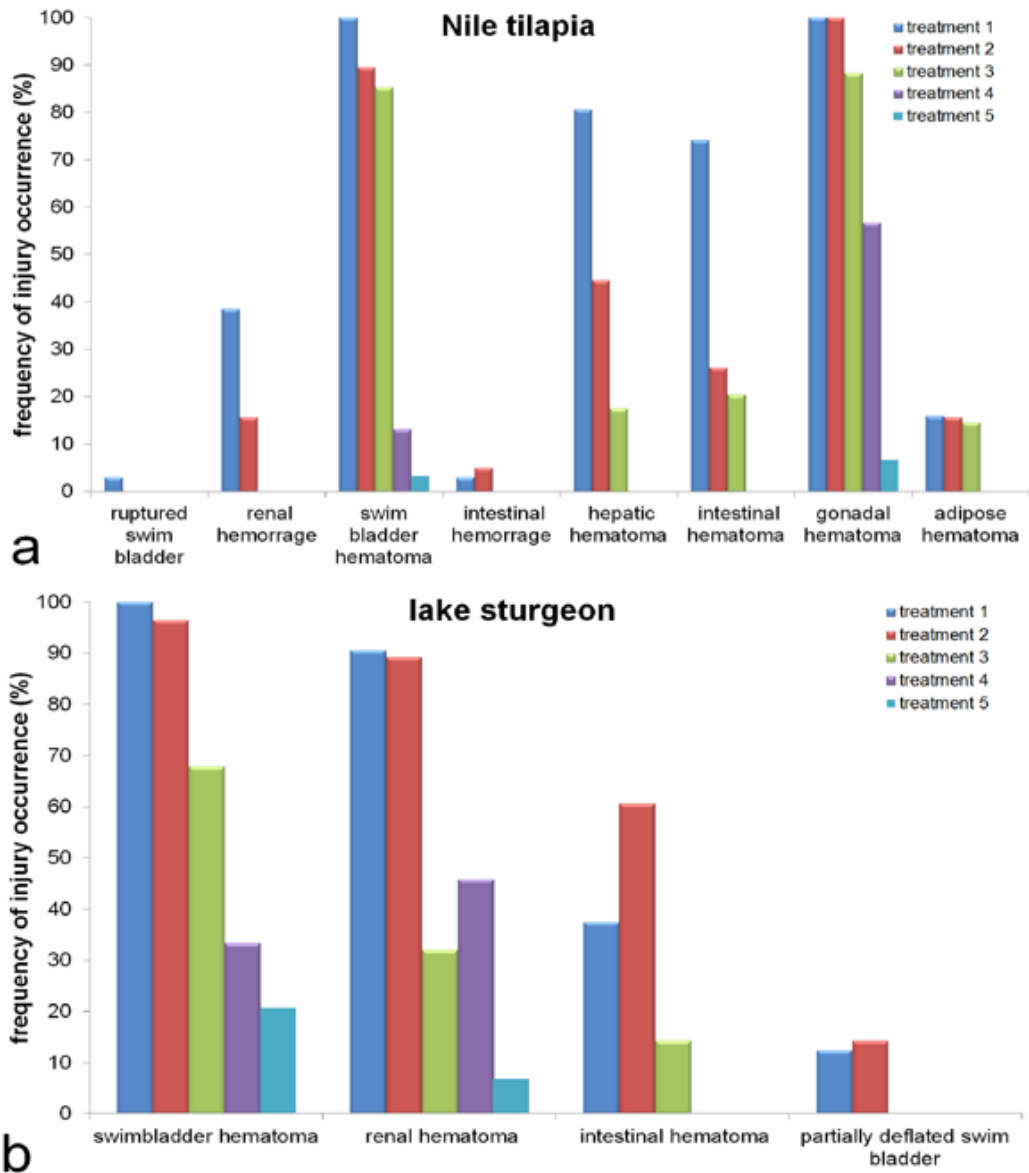

Figure 5.4. Frequency of occurrence of injuries. Frequency of occurrence of the different types of injuries observed at each of the treatment levels in the Nile tilapia (A) and lake sturgeon (B).



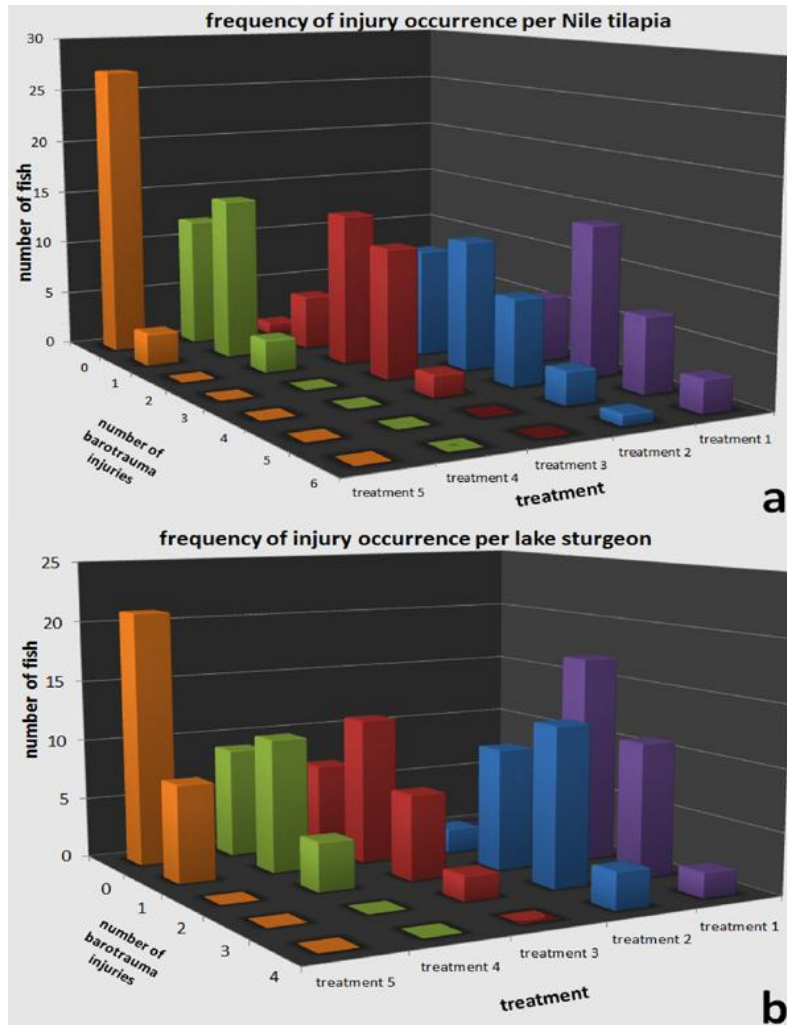

Figure 5.5. Number of injuries observed in each fish. Shows injuries at each of the treatment levels for the Nile tilapia (A) and lake sturgeon (B).

The RWI values in lake sturgeon also followed a similar pattern (Figure 5.6). Even though there was a slight increase in the average RWI values at Treatment 2 compared with Treatment 1 (17.7 and 18.9 respectively) there was no significant difference between those RWI values (Table 5.3). Following a statistically significant drop in RWI value between Treatment 2 and Treatment 3 (average RWI value of 5.3), and between Treatments 3 and 4 (average RWI value of 2.9). There was, however, no significant difference between Treatments 4 and 5 (average RWI value of 0.4).

Figure 5.6. Average RWI values.

Data for each SEL<sub>cum</sub> (A) and SEL<sub>ss</sub> (B) treatment level. There is only one data point for the hogchoker as they were only tested at the loudest treatment level with no resulting injuries observed. Salmon data obtained from Halvorsen *et al.* (6). Standard deviation bars are included for the lake sturgeon and Nile tilapia.

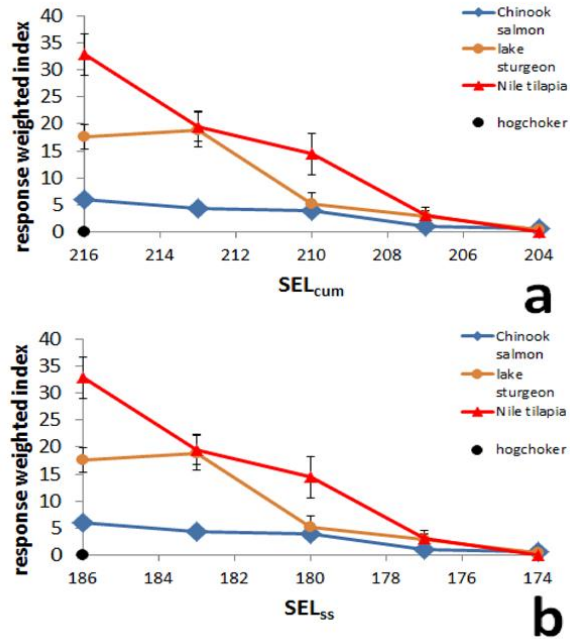

Table 5.3. Statistical analyses of RWI values for sturgeon and tilapia.

Species	RWI Value	ANOVA	F Values	p Values
Lake Sturgeon	Treatment 1-5	ANOVA	$F_{4, 113} = 8.046$	$p < 0.001$
	Treatment 1 and 2	Post-hoc		$p = 0.985$
	Treatment 2 and 3	Post-hoc		$p < 0.001$
	Treatment 3 and 4	Post-hoc		$p = 0.027$
	Treatment 4 and 5	Post-hoc		$p = 0.425$
Nile Tilapia	Treatment 1-5	ANOVA	$F_{4, 123} = 9.330$	$p < 0.001$
	Treatment 1 and 2	Post-hoc		$p < 0.001$
	Treatment 2 and 3	Post-hoc		$p < 0.001$
	Treatment 3 and 4	Post-hoc		$p < 0.001$
	Treatment 4 and 5	Post-hoc		$p = 0.052$

Eight different injuries were observed in the Nile tilapia including ruptured swim bladders, hemorrhaging of the kidney and intestines, and hematomas on the swim bladder, liver, intestines, gonads, and adipose tissue (Figure 5.4). The highest average number of injuries per fish was observed in Treatment 1 with a significantly decreasing trend as sound levels were lowered, (Table 5.2; Figure 5.5). The RWI values observed at each treatment level also showed a significant decrease from Treatment 1 through Treatment 4, but not between Treatments 4 and 5 (Table 5.3; Figure 5.6).

Comparisons were made between RWI values as well as between the average number of injuries per fish at each of the treatment levels between the Nile tilapia, lake sturgeon, and data previously collected with the Chinook salmon (Halvorsen *et al.* 2011, 2012) (Figure 5.6). It should be noted that a spleen hemorrhage was found in one lake sturgeon but was not included in this analysis as this injury was not included in the previous Chinook salmon study. The low

frequency of occurrence of this injury (0.007% of all exposed fish) would have only a negligible effect on the RWI values in lake sturgeon for that treatment.

For Treatment 1, both the number of injuries per fish (Table 5.4) and RWI values (Table 5.5) were significantly different between the lake sturgeon, Nile tilapia, and Chinook salmon. In Treatment 2, the number of injuries and the RWI values were significantly different between salmon and tilapia and between salmon and sturgeon in that there were more injuries and higher RWI values for tilapia and sturgeon respectively (Table 5.5). For Treatment 3, both variables were significantly different among all of the species except Chinook salmon and lake sturgeon (Tables 5.4, 5.5). In Treatments 4 and 5 there was no significant difference in values for either variable among any of the fishes (Tables 5.4, 5.5).

Table 5.4. Statistical analyses of number of injuries between each species.

Species	Number of Injuries	ANOVA	F Values	p Values
Lake Sturgeon vs. Chinook Salmon	Species Comparison	ANOVA	$F_{4, 277} = 8.736$	$p < 0.001$
	Treatment 1	ANOVA		$p < 0.001$
	Treatment 2	ANOVA		$p = 0.001$
	Treatment 3	ANOVA		$p = 0.240$
	Treatment 4	ANOVA		$p = 0.070$
	Treatment 5	ANOVA		$p = 0.345$
Lake Sturgeon vs. Nile Tilapia	Species Comparison	ANOVA	$F_{4, 294} = 15.431$	$p < 0.001$
	Treatment 1	ANOVA		$p < 0.001$
	Treatment 2	ANOVA		$p = 0.106$
	Treatment 3	ANOVA		$p < 0.001$
	Treatment 4	ANOVA		$p = 0.683$
	Treatment 5	ANOVA		$p = 0.411$
Chinook Salmon vs. Nile Tilapia	Species Comparison	ANOVA	$F_{4, 299} = 6.937$	$p < 0.001$
	Treatment 1	ANOVA		$p < 0.001$
	Treatment 2	ANOVA		$p < 0.001$
	Treatment 3	ANOVA		$p < 0.001$
	Treatment 4	ANOVA		$p = 0.174$
	Treatment 5	ANOVA		$p = 0.096$

Salmon data obtained from Halvorsen *et al.* (2011)

Table 5.5. Statistical analyses of RWI values between each species.

Species	RWI Values	ANOVA	F Values	p Values
Lake Sturgeon vs. Chinook Salmon	Species Comparison	ANOVA	$F_{4, 277} = 143.204$	$p < 0.001$
	Treatment 1	Post-hoc		$p < 0.001$
	Treatment 2	Post-hoc		$p < 0.001$
	Treatment 3	Post-hoc		$p = 0.092$
	Treatment 4	Post-hoc		$p = 0.788$
	Treatment 5	Post-hoc		$p = 0.272$
Lake Sturgeon vs. Nile Tilapia	Species Comparison	ANOVA	$F_{4, 294} = 76.398$	$p < 0.001$
	Treatment 1	Post-hoc		$p < 0.001$
	Treatment 2	Post-hoc		$p = 0.926$
	Treatment 3	Post-hoc		$p < 0.001$
	Treatment 4	Post-hoc		$p = 0.506$
	Treatment 5	Post-hoc		$p = 0.904$
Chinook Salmon vs. Nile Tilapia	Species Comparison	ANOVA	$F_{4, 299} = 202.973$	$p < 0.001$
	Treatment 1	Post-hoc		$p < 0.001$
	Treatment 2	Post-hoc		$p < 0.001$
	Treatment 3	Post-hoc		$p < 0.001$
	Treatment 4	Post-hoc		$p = 0.363$
	Treatment 5	Post-hoc		$p = 0.299$

Salmon data obtained from Halvorsen *et al.* (2011)

## 5.4 Discussion

The results of this study show that each species yielded different injury responses to the pile driving stimuli, especially at the highest sound levels (Figure 5.6). However, as SEL levels decreased, the responses between fishes became similar. The variability in results at the higher levels is could potentially be a function of the presence or absence of a swim bladder, and the difference in physostomous vs. physoclistous swim bladder.

Variability is most evident when comparing the other tested species to the hogchoker. As a representative species without a swim bladder, there was no visual evidence of any external or internal injuries in hogchoker at Treatment 1 (Figure 5.1). It is possible that there could have been a delay in the onset of injuries, which could have appeared in the days following exposure, but a recent study (Casper *et al.* 2012a) did not find evidence to support onset of new injuries in the days post-exposure in juvenile Chinook salmon.

However, those post exposure analyses were not performed in hogchoker due to the availability of only a limited number of animals. Many species of flatfishes are considered commercially important, and the physiology among flounder and sole are fairly similar, which suggests that these fishes would be able to survive pile driving exposures up to 960 strikes at levels equivalent to Treatment 1 without sustaining damage. Follow up studies could focus on other fishes without swim bladders to investigate the consistency of injuries in other fish families. Specifically, testing elasmobranch fishes could be valuable since their physiology is unique among other fishes without swim bladders and many of these species are under pressure from other anthropogenic causes (Casper *et al.* 2012b).

The Nile tilapia yielded the highest average RWI value at Treatment 1 of all of the tested species (Figure 5.6) with several *Moderate injuries* including 100% occurrence of swim bladder and gonadal hematomas as well as high levels of hepatic and intestinal hematomas. There was also a 38% occurrence of *Mortal* renal hemorrhaging and one ruptured swim bladder. This was not surprising as the physoclistous swim bladder of this fish is incapable of quickly modulating its mass of gas thereby making it much more susceptible to damage from overexpansion. All of the injuries observed from Treatment 1 were also present in Treatment 2 (Figure 5.4), though the frequency of occurrence decreased resulting in a large decline in the average RWI value. Hematomas of the swim bladder and gonads remained through Treatment 2 and 3 and even remained, albeit at a lower frequency, throughout Treatment 5 suggesting that these organs were the most sensitive to barotrauma. Any damage, even hematomas, to the reproductive organs could be significant at a population level if it resulted in a long term decrease in the reproductive output of these fishes, though this was not measured within this study.

When compared with the Chinook salmon, Nile tilapia had higher average RWI levels for Treatments 1-3. For the Nile tilapia in Treatment 3, the RWI values and number of injuries were statistically higher than Chinook salmon from Halvorsen *et al.* (2011, 2012) study, which suggests that Nile tilapia are more sensitive to pile driving than the previously tested juvenile Chinook salmon. This could be an important finding for physoclistous fishes, yet there are many physiologically diverse physoclistous species thus further testing would be necessary to make any generalizations.

The lake sturgeon RWI values were higher than the Chinook salmon (Halvorsen et al. 2011, 2012) and lower than the Nile tilapia when exposed to Treatment 1 (Figure 5.6). Like the Chinook salmon and other salmonids, sturgeon have a physostomous swim bladder which, while sensitive to damage from pile driving, does not appear to be as damaging to surrounding tissues as the physoclistous swim bladder in the Nile tilapia. The most common injuries observed were hematomas of the swim bladder, liver, and intestine, all of which could result from overexpansion of the swim bladder.

For the lake sturgeon, it is important to note that after Treatment 2, the RWI values were not significantly different from Chinook salmon, suggesting the overall responses between the two fishes are biologically similar. Treatment 3 used equivalent sound level metrics as those in Halvorsen *et al.* (2011, 2012) and those sound levels helped define the threshold of injury onset in Chinook salmon (the threshold being an RWI value of  $\geq 2$ ).

It is interesting to note the diversity of injuries between the Nile tilapia, lake sturgeon, and Chinook salmon. While there was a small overlap between the three species (swim bladder and intestinal hematoma), there were many more types of injuries (Stadler and Woodbury 2009) observed in the Chinook salmon (Halvorsen et al. 2011, 2012) and Nile tilapia (10) than in the lake sturgeon (5) at equivalent treatment levels and number of pile strikes. There are many potential reasons for this diversity, with the most likely being anatomical and physiological differences between species. Looking at the morphology of swim bladders between the three species, the Chinook salmon and Nile tilapia have swim bladders that extend the length of the internal cavity thereby take up a large portion of the abdomen of the fish while the lake sturgeon swim bladder is much smaller and located more anteriorly. The swim bladder location within the lake sturgeon is not in as close proximity to as many internal organs as it is in the other species,

thus decreasing the potential to cause damage. Future studies should make certain to not only consider the type of swim bladder (physostomous/physoclistous) but also the size and location within the abdomen.

A possible explanation for the diversity of observed injuries is the size and general body shape of the different species. The lake sturgeon were significantly smaller in standard length as well as weight compared with the other species. Of the lake sturgeon, 92% were less than 2 g (none of the Chinook salmon or Nile tilapia were less than 6 g), a weight that has previously been hypothesized as having the potential to be more susceptible to injury than fishes larger than 2 g (Carlson et al. 2007) based on a previous study looking at underwater explosive damage in different sizes of fishes (Yelverton et al. 1975). There is no evidence to support or refute this claim within the confines of this study as so few lake sturgeon larger than 2 g were tested. The differences in body shape between these species could also be an important factor, however this variable was not specifically addressed in this study but would be a valuable exercise in a future experiment that could incorporate more examples of these and other body shapes.

Another important aspect of this study is that it supplies data that can be considered for use to inform decision makers considering regulatory criteria for exposure of fish to pile driving sounds. The current guidelines developed on the U.S. West Coast for maximum sound exposure levels to which fish can be exposed during pile driving before onset of injury are a  $SEL_{cum}$  of 187 dB re  $1 \mu Pa^2 \cdot s$  for fishes above 2 g and a  $SEL_{cum}$  of 183 dB re  $1 \mu Pa^2 \cdot s$  for fishes below 2 g (Stadler and Woodbury 2009; Woodbury and Stadler 2008). As four fish species that represent the range of swim bladder physiology and without swim bladder have now been exposed in the HICI-FT, results may support potentially increasing current criteria levels to 207 dB re  $1 \mu Pa^2 \cdot s$   $SEL_{cum}$  derived from 177 dB re  $1 \mu Pa^2 \cdot s$   $SEL_{ss}$  and 960 impulsive signals, as suggested by Halvorsen *et al.* (Halvorsen et al. 2011, 2012). In other words, the data from the HICI-FT studies support an argument that some fishes may be less susceptible to energy from impulsive pile driving than is currently allowed before onset of physiologically significant injuries.

This study provides a new understanding of the importance of the swim bladder in fishes exposed to impulsive pile driving. The results from this study can lead scientists and regulators to understand and potentially predict the kinds of injuries that might appear in fishes when there is a general understanding of the fish's specific anatomy/physiology. With further testing, these predictions will become more refined for setting regulations with pile driving projects.

## 6.0 General Conclusions

A discussion of the results of each of these studies was included in their respective sections. This section brings together the findings from the overall project and considers the implications of the results for effects of pile driving on fishes.

### 6.1 Overview of Results

These studies represent the first laboratory-based investigation of the effects of exposure to pile driving signals on fishes. Moreover, this is also the first suite of studies of the effects on fishes of any impulsive sound source using conditions in which there was control over the stimulus including intensity, spectrum, duration, etc. In contrast to the work reported here, earlier studies have been conducted in the field where actual pile driving was used as the stimulus. However, with the exception of several studies on effects of seismic air guns (McCauley et al. 2003; Popper et al. 2005; Song et al. 2008; Hastings et al. 2008), there were poor or no stimulus controls (reviewed in Popper and Hastings 2009a).

Earlier pile driving studies have all been done in the field where the investigators dealt with actual pile driving operations (reviewed in Popper and Hastings 2009a; also Caltrans 2002, 2010a, b; Abbot et al. 2005; Nedwell et al. 2006; Ruggerone et al. 2008) where there was no control over the stimulus presentation. In addition, these studies often lacked appropriate experimental controls and, with the exception of the most recent studies (e.g., Caltrans 2010a, b), the necropsies were performed by investigators without proper training in procedures for handling animals.

#### 6.1.1 Study Design

Several aspects of the present study are of particular note. First, the study incorporated a specially designed apparatus (HICI-FT) that essentially brought pile driving exposures into a controlled laboratory setting. The signals inside the HICI-FT were under far-field plane wave acoustic conditions which is the equivalent of placing the fish 10 meters away from the source.

Second, the HICI-FT enabled use of actual pile driving signals. These signals maintained a high fidelity to the signals recorded in the field in shape, spectra, and level in both pressure and particle motion components. Furthermore, the study was able to control the number, level, spectrum, and time between strikes.

Third, the HICI-FT allowed for control over the amount of pressure and/or particle motion through the independent control of each shaker. Controlling the components of sound enables the presentation of near-field or far-field signals, and pure particle velocity or pure pressure signal types. However, the time needed to accommodate all of these variables was beyond the scope of this effort. Thus these studies focused on far-field plane wave exposures since the majority of exposed fish would be in the acoustic far-field. At the same time, a recommendation from these studies is that future work using a HICI-FT-like instrument should focus on the sound signals found closer to the source.

It should also be noted that the initial study (Section 3) took about 18 months while the subsequent studies each took 3 to 6 months. This decrease in time mostly came from following the protocols established in the initial study and experience in doing the experiments. But, the decrease is also attributed to the thorough exploration of the study space in terms of number of strikes as well as SELs which provided the bounds for the follow on studies. Thus, after the initial study, the follow on studies made use of the earlier data and experimental design to constrain the experimental parameters that focused the collection of data.

### **6.1.2 Recovery from Effects of Exposure**

The results from these studies demonstrate that the severity of injury in different fish species was related to the SEL of each strike and the total number of strikes, which together gives the cumulative SEL. At the maximum SEL<sub>cum</sub> presented in this study, mortal injuries were observed; while as the SEL<sub>cum</sub> decreased, there was a decrease of injury severity into a range that was below the threshold at which no injuries were found.

As documented in the experiments in Section 4, Chinook salmon healed from their injuries, and similar results have been found for striped bass (Section 1.6.4.1). However, the recovery studies were done in the laboratory where fish were not subject to natural stressors. As pointed out in Section 4, if fish with the same injuries were in the wild, their sustained injuries could result in a decreased ability to survive and escape predation.

One of the motivations behind the recovery studies was to determine if injuries showed up a few days after exposure. The rationale was that subcellular effects that would not be seen during necropsy on the exposure day might manifest over time. However, findings for both Chinook salmon (Section 4) and striped bass (Section 1.6.4.1) showed that no additional effects were found during the recovery period, and, indeed, healing of injuries was observed. At the same time, preliminary work in Nile tilapia and striped bass showed that damage to the sensory cells of the inner ear did not show up for several days (Sections 1.6.4.2 and 6.1.3), as demonstrated earlier (Hastings et al. 1996; McCauley et al. 2003).

### **6.1.3 Effects on Inner Ear Tissues and Hearing – Preliminary Results**

Assessment of the sensory hair cells, in striped bass and Nile tilapia, was investigated immediately and a few days after exposure. Unlike tissue damage, hair cell damage manifested about four days post-exposure (Section 1.6.4.2). However, this finding was consistent with earlier studies of effects of intense pure tones and also seismic air guns on fish inner ear tissue (Hastings et al. 1996; McCauley et al. 2003). At the same time, it should be noted that not all exposures to high intensity sounds result in damage to sensory cells of the inner ear (e.g., Popper et al. 2005, 2007; Song et al. 2008; Kane et al. 2010). The likely cause of the delayed effect is that the damage to the sensory cells of the inner ear are subcellular and result from mechanical movements of the otoliths (ear stone of the inner ear) relative to the sensory cells.

The preliminary results also showed recovery in the inner ear after about eight days post-exposure. This is not unexpected since it is known that fish inner ears constantly produce sensory hair cells throughout life (e.g., Popper and Hoxter 1984; Lombarte and Popper 1994) and so damaged hair cells are likely replaced by new cells.



With the loss of sensory hair cells, a question that arises is whether this loss has any effect on the ability of fish to hear. While it was not possible to do studies of hearing following exposure in the HICI-FT, the loss of sensory cells does suggest a potential temporary loss of hearing, as documented in goldfish by Smith et al. (2006). However, the number of sensory cells damaged was a small proportion of total number of sensory cells. Thus a loss of hearing may be minimal or not occur at all. Future studies are needed to examine this issue in greater detail.

#### **6.1.4 Generality of Findings to Other Fishes**

The overall results documented barotrauma effects in the five different tested species, other than the hogchoker in which no injuries were observed. At the highest SELs, there was diversity of the observed barotrauma injuries between the various species. Such diversity is likely due to the distinctive anatomical and physiological types (i.e. physostomous and physoclistous swim bladders) represented. As the SELs decreased, the responses of each species became more similar to one another. Data are still needed to test and compare between other species, however the data in this report suggest a response similarity that may apply to other species at the lowest SELs presented here.

When generalizing the results, there are a few caveats, one of which is the size of fish which was constrained in these studies by the size of the HICI-FT chamber. Thus, while the study in Section 1.6.4.2 tested two sizes of striped bass, and found similar results, the size class differences were small and may not have been sufficient to show an effect within the species. Indeed, Carlson et al. (2007) predicted that there would be less barotrauma in larger fish, and this resulted in the Fisheries Hydroacoustics Working Group (FHWG) applying different onset criteria for fish under 2 g and fish over 2 g (e.g., Stadler and Woodbury 2009; Woodbury and Stadler 2008). Future studies are needed to examine the relationship between effects from impulsive sources and fish of differing sizes.

#### **6.1.5 Implications for Behavior**

Impulsive sounds travel great distances from their source and fish will likely hear these sounds out to a distance that is substantially greater than the distance over which fish may suffer barotrauma. Indeed, fish have a higher probability of hearing pile driving sounds before they are close enough to be injured. It is often theorized that fish would swim away from impulsive sounds when the signals are below those that cause damage. However, at this time there is no data to support those theories. These questions remain mostly unanswered except for a few of studies (e.g., Lokkeborg et al. 2012).

It is important to note that the data in these studies do not address behavior. While a video camera was present inside the HICI-FT, the field of view of the camera was very limited and only allowed occasional glimpses of fish. Indeed, behavior of fish in a tank or cage is abnormal and not representative of normal fish behavior in the wild (Popper et al. 2007; Hawkins and Popper 2012).

Though behavior is not part of the present study, it is recommended that future studies incorporate behavior during exposure to pile driving. Questions that need to be addressed concern: how fish react when they hear the sounds; the kind(s) of behavioral responses elicited;

the received sound levels at which behavioral responses start; how behavioral responses vary by species, fish size, and/or age; and if “ramp up” procedures induce fish evacuation of an area to avoid being affected by the damaging impulsive sound levels.

## 6.2 Overall Consideration of Findings

The results from these studies are the first to quantify the effects of impulsive sounds on fishes. They are also the first that can provide science-based data useful for developing criteria for impulsive sources.

As discussed in Section 1.4, the interim criteria in use by NMFS on the U.S. West Coast are  $SPL_{peak}$  of 206 dB re 1  $\mu Pa$  and  $SEL_{cum}$  of 187 dB re 1  $\mu Pa^2 \cdot s$  for fishes above 2 g and a  $SEL_{cum}$  of 183 dB re 1  $\mu Pa^2 \cdot s$  for fishes below 2 g. The NMFS also accepted the idea that there is a “resetting” of  $SEL_{cum}$  after 12 hours of non-exposure, after which time the exposure would again be reset to 0 (Stadler and Woodbury 2009).

Results from the study in Section 3 defined an onset of injury in Chinook salmon at an  $SEL_{cum}$  of over 210 dB re 1  $\mu Pa^2 \cdot s$  derived from 960 strikes and  $SEL_{ss}$  of 180 dB re 1  $\mu Pa^2 \cdot s$ , at these levels most of the other species were still showing moderate to mortal injuries. It wasn't until the  $SEL_{cum}$  was 207 re 1  $\mu Pa^2 \cdot s$  that the other species had comparable injury scores to the Chinook salmon, suggesting other species may be slightly more sensitive and might have a slightly lower threshold. It is important to note the metrics used to define threshold include the number of strikes and the  $SEL_{ss}$  levels that yield the  $SEL_{cum}$  values (Section 3.3).

## 6.3 General Conclusions

### 6.3.1 Findings

The following conclusions come from this suite of studies:

- For all species studied, onset of barotrauma effects did not occur until the  $SEL_{cum}$  was substantially above the current NMFS interim regulations.
- No barotrauma injuries were observed in a species without a swim bladder (hogchoker).
- There were differences in the sound exposure level at which barotrauma appeared in fish. In the most sensitive tested species barotrauma was seen at an  $SEL_{cum}$  of 207 dB re 1  $\mu Pa^2 \cdot s$  yielded from  $SEL_{ss}$  177 dB re 1  $\mu Pa^2 \cdot s$  and 960 strikes.
- The important metrics used to define the impulsive exposure incorporate how the energy accumulated. Three recommended metrics are:  $SEL_{cum}$ ,  $SEL_{ss}$  and the number of strikes.
- Fish with an RWI score of 2 or less showed recovery from injuries in a laboratory setting.

- The barotrauma effects seen immediately after exposure appeared to represent the full suite of barotrauma injuries for a particular set of signal parameters. Over time, fish recovered from moderate injuries and new injuries did not appear.
- Effects from exposure to pile driving sounds appear to be consistent across species, even when there are substantial differences in fish morphology, including in both physostomous and physoclistous fishes. It is likely that the greater portion of effects result from rapid, repeated, and high amplitude motions of the walls of the swim bladder “pounding” on nearby tissues (gut, kidney, gonads).

### 6.3.2 Future Studies

The following studies are recommended for future investigation on effects of pile driving on fishes.

- *Effects of pile driving sounds on additional species, including pelagic fishes without a swim bladder such as sharks.* Sharks lack a swim bladder, and it is possible that effects would differ from flatfish tested here (Casper et al. 2012a).
- *Effects on fishes at different depths (See Section 3).* Impulsive sound generating activity and fish are located at various depths in the ocean. Studies on fish subjected to rapid decompression have shown that the extent of barotrauma injury is dependent on a ratio of pressure to which fish are acclimated and the exposure pressure. The current configuration of the HICI-FT simulates exposure at the water surface only. Fish are also found at depths below the water surface and thus a redesign to pressurize the HIC-FT would allow studies to investigate depth to take place.
- *Effects on fishes sitting on the bottom exposed to sub-surface waves.* Pile driving sounds not only propagate through the water, but that they also propagate through the substrate (e.g., Popper and Hastings 2009a). These sound waves could potentially impact fish living on the bottom.
- *Effects on fishes in the near field where particle motion is high.* As indicated in Section 1, the experiments were designed to work in the plane wave environment. because most fishes exposed to pile driving (or other impact sources) will be in the far-field. At the same time, some fishes will be closer to the source with particle motion as the dominant part of the sound field. Thus, it will ultimately be of interest to ascertain the effects of near-field particle motion on fishes.
- *Effects on hearing.* There is evidence (Section 1.6.4.2) that exposure to high levels of pile driving sounds can damage sensory hair cells of the ear. However fishes regenerate damaged hair cells and thus replace those lost. However, it will be important to determine if there is an actual change in hearing threshold from this minor and temporary loss of hair cells.
- *Relationship between number of pile strikes and onset of damage.* It is unknown if barotrauma appears after the first impulsive sound or after the 1000<sup>th</sup> impulsive

sound. Experiments addressing the timing of barotrauma appearance would be helpful in further understanding the impacts.

- *Effects of “recovery times” between pile strikes:* During pile driving activities there are natural breaks in activity such as equipment repair, hammer adjustment, etc. Assumptions exist that some recovery from damage occurs during these breaks and suggest that the cumulative effects of impulsive sounds might reset in fish. Thus, recovery during ‘breaks’ should be investigated. Furthermore, if this assumption is true, the effects on fish might differ between 1000 continuous strikes compared to 100 strikes presented 10 times with a break in between. This paradigm would help address the influence of natural breaks on injury occurrence.
- *Effects on fishes of different sizes.* The size of fish that could be used was limited by the inside of the HICI-FT. It would be valuable to study effects on larger fish. However, the HICI-FT is a high precision apparatus and would require a remodel to enlarge all components such as the chamber, shakers, etc.
- *Effects on different species:* This study used species with substantial morphological and physiological diversity (e.g., Chapter 5). However, fishes are, by far, the most diverse (and largest) of all vertebrate groups and so additional species, representing additional body shapes, ecologies, physiologies, etc. are needed to better document effects.
- *Recovery of effects in stressed fish:* The recovery studies held fish up to 14 days in the laboratory, and thus do not represent a realistic environment. A way to determine recovery-rates in a realistic manner would be to implement a performance-challenge strategy such as a swim challenge using a flume or implement a health challenge with exposure to a bacterial disease on fish post impulsive sound exposure. The injury effects could be quickly assessed under realistic and controlled stress conditions.
- *Effects on other aspects of physiology:* While this study focused on barotrauma, there are other potential physiological effects, such as changes in hormonal levels and/or immune responses resulting from stress, that could impact long-term health, growth, and survival. Future studies might incorporate analysis of both direct measures of hormonal changes and related physiological measures and challenges to assess the impact of pile driving.

## 7.0 Literature Cited

- Abbott R., J. Reyff, G. Marty. 2005. Final Report: Monitoring the effects of conventional pile driving on three species of fish. San Rafael, CA: Strategic Environmental Consulting, Inc. 1-137 p.
- Bolle L. J. , C. A. F. de Jong, S. M. Bierman, P. J. G. van Beek, O. A. van Keeken, P. W. Wessels, C. J. G. van Damme, H. V. Winter, D. de Haan, R. P. A. Dekeling. 2012. Common sole larvae survive high levels of pile-driving sound in controlled exposure experiments. PLoS ONE 7: 1-12.
- Brown, R. S., T. J. Carlson, A. E. Welch, J. R. Stephenson, C. S. Abernethy, D. C. Ebberts, M. J. Langeslay, M. L. Ahmann, D. H. Feil, J. R. Skalski, and R. I. Townsend. 2009. Assessment of barotrauma from rapid decompression of depth-acclimated juvenile Chinook salmon bearing radiotelemetry transmitters. Transactions of the American Fisheries Society 138:1285-1301.
- Burns K. 2008. Evaluation of the efficacy of the current minimum size regulations for selected reef fish based on release mortality and fish physiology. Sarasota: Mote Marine Laboratory Technical Report # 1176, funded by NOAA under MARFIN Grant # NA17FF2010. 1-75 p.
- Burns K. M. 2009. Evaluation of the efficacy of the minimum size rule in the red grouper and red snapper fisheries with respect to J and circle hook mortality, barotrauma and consequences for survival and movement [PhD Thesis]. Tampa: University of South Florida, pp 1–202. Univ. of South Florida website. Accessed 2012 May 24.
- California Department of Transportation (Caltrans). 2002. Biological Assessment for the Benicia Martinez new bridge project for NOAA Fisheries. California Department of Transportation. 1-24 p.
- California Department of Transportation (Caltrans). 2010a. Effects of pile driving sound on juvenile steelhead. ICF Jones & Stokes.  
[http://www.dot.ca.gov/hq/env/bio/files/madriver\\_cagedfish.pdf](http://www.dot.ca.gov/hq/env/bio/files/madriver_cagedfish.pdf)
- California Department of Transportation (Caltrans). 2010b. Necropsy and histopathology of steelhead trout exposed to steel pile driving at the Mad River Bridges, U.S. Highway 101.
- Carlson T. J., M. C. Hastings, and A. N. Popper. 2007. Update on recommendations for revised Interim Sound Exposure Criteria for Fish During Pile Driving Activities, Memorandum to S. Theiss (California Department of Transportation) and P. Wagner (Washington State Department of Transportation). Pacific Northwest National Laboratory: Richland, WA, USA. (last update 9/21/2012) [http://www.dot.ca.gov/hq/env/bio/files/ct-arlington\\_memo\\_12-21-07.pdf](http://www.dot.ca.gov/hq/env/bio/files/ct-arlington_memo_12-21-07.pdf)
- Carlson TJ, Johnson GE, Woodley CM, J.R. S, A.G. S. 2011. Compliance monitoring of underwater blasting for rock removal at Warrior Point, Columbia River channel improvement project 2009/2010. PNNL-20388, for the USACE Portland District, Portland Oregon by Pacific Northwest National Laboratory, Richland, Washington. 1-90 p.
- Casper, B. M., M. B. Halvorsen and A. N. Popper. 2012b. Are sharks even bothered by a noisy environment? In: Popper, A. N. and A. D. Hawkins, eds. The Effects of Noise on Aquatic Life, New York: Springer, pp. 93-97.

- Casper, B. M., A. N. Popper, F. Matthews, T. J. Carlson, and M. B. Halvorsen. 2012a. Recovery of barotrauma injuries in Chinook salmon, *Oncorhynchus tshawytscha* from exposure to pile driving sound. *PloS One*. 7(6):e39593.
- Champion, H. R. 2002. Trauma Scoring. *Scandinavian Journal of Surgery* 91:12-22.
- Chawda, M. N., F. Hildebrand, H. C. Pape, and P.V. Giannoudis. 2004. Predicting outcome after multiple trauma: which scoring system? *Injury, International Journal of Care Injured* 35: 347-358.
- Davis R. I., W. Qiu, and R. P. Hamernik. 2009. Role of the Kurtosis Statistic in Evaluating Complex Noise Exposures for the Protection of Hearing. *Ear and Hearing* 30: 628-634.
- Gaspin, J. B. 1975. Experimental investigation of the effects of underwater explosions on swimbladder fish, 1: 1973 Chesapeake Bay Tests. Naval Surface Weapons Center, Silver Spring, MD 20910. SWC/WOL/TR 75-58.
- Govoni J. J., L.R. Settle, and M. A. West. 2003. Trauma to juvenile pinfish and spot inflicted by submarine detonations. *Journal of Aquatic Animal Health* 15:111-119.
- Govoni J. J., M.A. West, L.R. Settle, R.T. Lynch and M.D. Greene. 2008. Effects of underwater explosions on larval fish: Implications for coastal engineering project. *Journal of Coastal Research* 24(sp 2): 228-233.
- Halvorsen, M. B., B. M. Casper., C. M. Woodley, T. J. Carlson and A. N. Popper. 2011. Predicting and mitigating hydroacoustic impacts on fish from pile installations. NCHRP Research Results Digest 363, Project 25-28, National Cooperative Highway Research Program, Transportation Research Board, National Academy of Sciences, Washington, D.C.
- Halvorsen, M. B., B. M. Casper, C. M. Woodley, T. J. Carlson and A. N. Popper. 2012a. Threshold for onset of injury in Chinook salmon from exposure to impulsive pile driving sounds. *PLoS ONE* 7: e38968
- Halvorsen MB, B.M. Casper, F. Matthews, T.J. Carlson, A.N. Popper. 2012b. Effects of exposure to pile-driving sounds on the lake sturgeon, Nile tilapia and hogchoker. *Proc. R. Soc. B* rspb20121544.
- Hamernik R. P. , W. Qiu, B. Davis. 2003. The effects of the amplitude distribution of equal energy exposures on noise-induced hearing loss: The kurtosis metric. *Journal of the Acoustical Society of America* 114: 386-396.
- Hastings M. C., C. A. Reid, C. C. Grebe, R. L. Hearn and J. G. Colman. 2008. The effects of seismic airgun noise on the hearing sensitivity of tropical reef fishes at Scott Reef, Western Australia. *Underwater Noise Measurement, Impact and Mitigation, Proceedings*.
- Hastings, M. C., A. N. Popper, J. J. Finneran and P. J. Lanford. 1996. Effects of low-frequency underwater sound on hair cells of the inner ear and lateral line of the teleost fish *Astronotus ocellatus*. *Journal of Acoustical Society of America* 99(3):1759-1767.
- Hawkins, A.D., and A. N. Popper. 2012. Effects of noise on fish, fisheries, and invertebrates in the U.S. Atlantic and Arctic from energy industry sound-generating activities: Literature synthesis. BOEM Contract M11PC00031 by Normandeau Associates, Inc. (last update 9/21/2012) [www.boemsoundworkshop.com](http://www.boemsoundworkshop.com).
- Husum H, and G. Strada. 2002. Measuring injury severity. The ISS as good as the NISS for penetrating injuries. *Prehosp. Disast. Med.* 17:27-32.
- Iwama, G. K., A. D. Pickering, J. P. Sumpter, and C. B. Schreck, editors. 1997. *Fish stress and health in aquaculture*. Cambridge University Press, Cambridge.

- Kane, A. S., J. Song, M. B. Halvorsen, D. L. Miller, J. D. Salierno, L. E. Wysocki, D. Zeddies and A. N. Popper. 2010. Exposure of fish to high intensity sonar does not induce acute pathology. *Journal of Fish Biology* 76:1825-1840.
- Krischer, J. P. 1979. Indexes of severity: Conceptual development. *Health Service Research* 14(1):56-67.
- Le Prell, C. G., D. Henderson, R. R. Fay and A. N. Popper (eds). 2012. *Noise-Induced Hearing Loss: Scientific Advances*, New York: Springer Science+Business Media, LLC..
- Lewis T.N., P. H. Rogers, J. S. Martin, G. S. McCall II, G. J. Lloyd GJ, et al. 1998. Test chamber for determining damage thresholds for high amplitude underwater sound exposure in animal models. *Journal Acoustical Society of America* 103: 2756.
- Løkkeborg, S., E. Ona, A. Vold and A. Salthaug. 2012. Sounds from seismic air guns: gear- and species-specific effects on catch rates and fish. *Canadian Journal of Fisheries and Aquatic Sciences* 69:1278-1291.
- Lombarte, A., and A. N. Popper. 1994. Quantitative analyses of postembryonic hair cell addition in the otolithic endorgans of the inner ear of the European hake, *Merluccius merluccius* (Gadiformes, Teleostei). *Journal of Comparative Neurology* 345:419-428.
- MacGillivray A., R. Racca. 2005. Sound Pressure and Particle Velocity Measurements from Marine Pile Driving at Eagle Harbor Maintenance Facility, Bainbridge Island, WA. Prepared by JASCO Research Ltd., Victoria, British Columbia, Canada: for WA Dept of Transportation. 1-15 p.
- Madsen, P. T. 2005. Marine mammals and noise: Problems with root mean square sound pressure levels for transients. *Journal of Acoustical Society of America* 117:3952-3957.
- Martin J. S., P. H. Rogers. 2008. Sound exposure chamber for assessing the effects of high-intensity sound on fish. *Bioacoustics* 17: 331-333.
- McCauley, R. D., J. Fewtrell, and A. N. Popper. 2003. High intensity anthropogenic sound damages fish ears. *Journal of Acoustical Society of America* 113(1):638-642.
- Nedwell J. R., A. W. H. Turnpenny, J. M. Lovel, and B. Edwards. 2006. An investigation into the effects of underwater piling noise on salmonids. *Journal of the Acoustical Society of America* 120: 2550-2554.
- Oyetunji, T, J.G., D. T. Crompton, E. R. Efron, D. C. Haut, E. E. Chang, S. P. Cornwell 3<sup>rd</sup>, P. Baker, and A. H. Haider. 2010. Simplifying physiologic injury severity measurement for predicting trauma outcomes. *J. Surg. Res.* 159(2):627-32.
- Popper A. N., T. J. Carlson, A. D. Hawkins, B. L. Southal, and R. L. Gentry. 2006. Interim criteria for injury of fish exposed to pile driving operations: A white paper. (last update 9/21/2012) [http://www.wsdot.wa.gov/NR/rdonlyres/84A6313A-9297-42C9-BFA6-750A691E1DB3/0/BA\\_PileDrivingInterimCriteria.pdf](http://www.wsdot.wa.gov/NR/rdonlyres/84A6313A-9297-42C9-BFA6-750A691E1DB3/0/BA_PileDrivingInterimCriteria.pdf)
- Popper A. N. and M. C. Hastings. 2009a. Effects of anthropogenic sources of sound on fishes. *Journal of Fish Biology* 75: 455-498.
- Popper, A. N. and M. C. Hastings. 2009b. The effects on fish of human-generated (anthropogenic) sound. *Integrative Zoology* 4: 43-52.
- Popper, A. N., and A. D. Hawkins (eds). 2012. *Effects of Noise on Aquatic Life*. New York: Springer Science + Business Media. 695 p.
- Popper, A. N., M. B. Halvorsen, A. Kane, D. Miller, M. E. Smith, J. Song, P. Stein, and L. E. Wysocki. 2007. The effects of high intensity, low frequency active sonar on rainbow trout. *Journal of Acoustical Society of America* 122 (1):623-635.

- Popper, A. N., M. E. Smith, P. A. Cott, B. W. Hanna, A. O. MacGillivray, M. E. Austin, and D. A. Mann. 2005. Effects of exposure to seismic airgun use on hearing of three fish species. *Journal of Acoustical Society of America* 117:3958-3971.
- Popper, A.N., and B. Hoxter. 1984. Growth of a fish ear: 1. Quantitative analysis of sensory hair cell and ganglion cell proliferation. *Hearing Research* 15:133-142.
- Roberto M, R. P. Hamernik, R. J. Salvi, D. Henderson and R. Milone. 1985. Impact noise and the equal energy hypothesis. *Journal of the Acoustical Society of America* 77: 1514-1520.
- Rogers, P. H., and T. Lewis. 1999. Test Chambers for LFS Animal Exposures. [in Rogers. P.H., Final Contract Report, Naval Contract N0014-97-1-0949 October 1999].
- Ruggerone G. T., S. E. Goodman and R. Miner. 2008. Behavioral Response and Survival of Juvenile Coho Salmon to Pile Driving Sounds. Natural Resources Consultants, Inc., Seattle, Washington: For Port of Seattle. (last update 9/21/2012)  
<http://home.comcast.net/~ruggerone/FishTerminalPileDriveStudy.pdf>
- Smith, M. E., A. B. Coffin, D. L. Miller, and A. N. Popper. 2006. Anatomical and functional recovery of the goldfish (*Carassius auratus*) ear following noise exposure. *Journal of Experimental Biology* 209:4193-4202.
- Song, J., D. A. Mann., P. A. Cott, B. W. Hanna and A. N. Popper. 2008. The inner ears of northern Canadian freshwater fishes following exposure to seismic air gun sounds. *Journal of the Acoustical Society of America* 124: 1360-1366.
- Stadler J. H., and D. P. Woodbury. 2009. Assessing the effects to fishes from pile driving: Application of new hydroacoustic criteria. Inter-Noise 2009, Ottawa, Ontario, Canada.
- Stephenson, J. R., A. J. Gingerich, R. S. Brown, B. D. Pflugrath, Z. Deng, T. J. Carlson, M. J. Langeslay, M. L. Ahmann, R. L. Johnson, and A. G. Seaburg. 2010. Assessing barotrauma in neutrally and negatively buoyant juvenile salmonids exposed to simulated hydro-turbine passage using a mobile aquatic barotrauma laboratory. *Fisheries Research* 106: 271-278.
- Woodbury, D., and J. Stadler. 2008. A proposed method to assess physical injury to fishes from underwater sound produced during pile driving. *Bioacoustics* 17(1-3):289-291.
- Yelverton, J. T., D. R. Richmond, W. Hicks, K. Saunders and E. R. Fletcher. 1975. The relationship between fish size and their response to underwater blast. Report DNA 3677T, Director, Defense Nuclear Agency, Washington, D.C.